



### Research Article

## Necessary height of the vertical stiffeners in steel silos on discrete supports

Lyubomir A. Zdravkov\*

Department of Metal, Wood and Plastic Structures, University of Architecture, Civil Engineering and Geodesy (UACEG), Sofia 1046, Bulgaria

### ABSTRACT

The steel silos are interesting complex facilities. In order to ensure unloading of whole amount of stored product by gravity, the steel silos are often placed on supporting frame structure. Values of stresses in the joints between the thin walled shell and supporting frame elements are very high. It can cause local loss of stability in the shell. To prevent its local buckling, many designers put stiffening elements above the supports. Here the question is how high should be the stiffening elements? The right solution is that they should reach that level till which the values of the meridional normal stresses above the supports and in the middle between them are equalized. Under this level the cylindrical shell will be considered as a ring beam, stiffened by elements above the supports. Above it, the cylinder can be calculated as continuously supported shell. But where is this level? A lot of researchers worked on values and way of distribution of normal meridional stresses above the supports of the cylindrical shells. As a result of their efforts are determined critical height  $H_{cr}$  of the shell and the ideal position  $H_I$  of intermediate stiffening ring. But these heights are considerably different between each other. To which of them our vertical stiffening elements should achieve?

### ARTICLE INFO

#### Article history:

Received 20 May 2018

Revised 12 October 2018

Accepted 30 October 2018

#### Keywords:

Steel silos

Meridional stress

Critical high

Vertical stiffener

Loss of stability

### 1. Introduction

Often steel silos are lifted facilities, placed on supporting structure. The purpose is to unload all stored product easily and completely by gravity. Supporting structure for every project is different, depending on real conditions of exploitation. The most popular are two types – built by horizontal girders and columns or by columns only. Both types frame structure cause concentration of meridional forces in the cylindrical body of the silos. As a result, the thin walled shell could lose local stability.

The simplest way to design steel silos is hypothetically to divide cylindrical shell on two parts - discretely supported ring beam and continuously supported shell above it. This conception is accepted by the European standard EN 1993-4-1, see Fig. 1. Obviously, to ensure continuous support of shell, bending stiffness of ring beam should be high. Unfortunately in EN 1993-4-1 is not mentioned the recommended stiffness of ring beam.

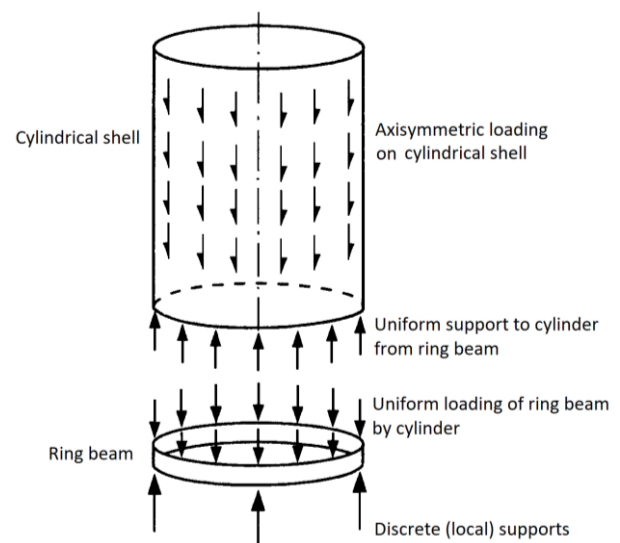

Fig. 1. Traditional design model for silos on discrete supports.

\* Corresponding author. Tel.: +359-885-081-305 ; E-mail address: zdravkov\_fce@uacg.bg (L. A. Zdravkov)

Rotter (1985) suggested that a value of ratio  $\psi = 0.25$  might be suitable for adoption in design, where:

$$\psi = \frac{K_{shell}}{K_{ring}}, \quad (1)$$

in which:  $K_{shell}$  is stiffness of cylindrical shell;  $K_{ring}$  - stiffness of ring beam.

Based on English translation of study of Vlasov (1961) about of curved beams, stiffness of ring beam  $K_{ring}$  is expressed as:

$$K_{ring} = \frac{(n^2-1)^2 E I_r}{R^4} \frac{1}{f_r}, \quad (2)$$

where:  $n$  is number of uniformly spaced supports;  $E$  - modulus of elasticity;  $I_r$  - moment of inertia about a radial axis;  $R$  - radius of ring beam centroid.

$$f_r = 1 + \frac{E I_r}{n^2 K_T}, \quad (3)$$

in which:

$$K_T = GJ + n^2 \frac{E C_w}{R^2}, \quad (4)$$

where:  $G$  is shear modulus;  $J$  - torsional constant;  $C_w$  - warping constant for an open sections.

Semimebrane theory of shells, proposed by Vlasov (1964), gives an expression of stiffness of cylindrical shell, as follow:

$$K_{shell} = n \sqrt{(n^2-1)} \frac{E}{\sqrt[3]{3}} \left(\frac{t}{R}\right)^{3/2} \frac{1}{f_s}, \quad (5)$$

where:  $t$  is a thickness of the cylindrical shell.

$$f_s = \frac{(e^\eta)^2 - 2e^\eta \sin(\eta) - 1}{(e^\eta)^2 - 2e^\eta \cos(\eta) + 1}, \quad (6)$$

in which:

$$\eta = \frac{2\pi H}{\mu}, \quad (7)$$

where:  $H$  is height of cylindrical shell;  $\mu$  - expressed by Calladine (1983) long wave bending half-wavelength:

$$\mu = \frac{2\pi \sqrt[3]{3}}{n \sqrt{(n^2-1)}} \sqrt{\frac{R}{t}} R. \quad (8)$$

Based on Eqs. (2) and (5), stiffness ratio  $\psi$  will look like as:

$$\psi = \frac{K_{shell}}{K_{ring}} = \frac{0.76(Rt)^2}{I_r} \sqrt{\frac{R}{t}} \sqrt{\frac{n^2}{(n^2-1)^3}} \frac{f_r}{f_s}, \quad (9)$$

For simplification, the Eq. (6) could be represented by two simple relations:

$$f_s = \begin{cases} \frac{\eta}{3}, & \text{when } H \leq H_{cr} \\ 1.0, & \text{when } H > H_{cr} \end{cases}, \quad (10)$$

where:  $H_{cr}$  is critical height of cylindrical shell. It could be determined by formula:

$$H_{cr} = \frac{3\sqrt[3]{3}}{n \sqrt{(n^2-1)}} \sqrt{\frac{R}{t}} R. \quad (11)$$

$H_{cr}$  represents the height of shell which is effective of redistributing of discrete forces from supports and equalizing of axial normal stresses. When height of shell  $H \leq H_{cr}$ , entire shell resists axial loads from supports. When  $H > H_{cr}$ , only that part between bottom of shell and critical height  $H_{cr}$  is effective in redistributing of vertical reactions from discrete columns.

In their researches Topkaya and Rotter (2011a, 2011b) conducted extensive finite element analyses for verification of Rotter's criterion about stiffness of ring beam. With 1280 separate finite-element analyses (FEA), covering two different types of ring sections, various heights and radii of cylindrical shells, the authors checked validity of suggested by Rotter (1985) ratio  $\psi = 0.25$ . On basis of done FEA they concluded, when a stiffness ratio  $\psi \leq 0.1$ , axial stresses will not deviate more than 25% from the uniform support assumption.

Later Topkaya and Rotter (2014) determined ideal location of intermediate stiffening rings on the shell. They expect a ring, placed at this ideal position, can effectively remove all circumferential nonuniformity in the axial membrane stress above it. The simple expression of ideal location  $H_l$  is:

$$H_l = \sqrt{12(1+\nu)} \frac{R}{n}, \quad (12)$$

where:  $\nu$  is Poisson's ratio.

Eq. (12) is verified by the authors using a total of 2400 finite element analyses.

Necessary stiffness of intermediate stiffening rings is determined by Zeybek et al. (2015). Stiffness ratio  $\chi$  could be expressed as:

$$\chi = \frac{K_{shell}}{K_{stiffener}} = \frac{Rt(A R^2 + I_x^2(n^2-1))}{12\sqrt{3}(1+\nu)^{1.5} A I_x n(n^2-1)^2}, \quad (13)$$

where:  $K_{shell}$  is circumferential stiffness of the shell;  $K_{stiffener}$  - circumferential stiffness of circular ring;  $A$  - cross sectional area of the stiffening ring;  $I_x$  - moment of inertia of the stiffening ring about vertical axis "x-x".

The results in research of Zeybek et al. (2015) indicate that ratios below about  $\chi < 0.2$  provide a satisfactorily uniform axial membrane stress distribution above the intermediate ring stiffener, so this limit is recommended for practical design. In his later research Zeybek et al. (2017) confirmed, that correlation smaller than  $\chi < 0.2$  are sufficient even when the rings are placed under their ideal position.

It should be noted that all above mentioned researches are done with smooth steel shells, without vertical stiffeners in them. On other side, common practice in design of steel structures is to place stiffening elements on the point, where are applied concentrated loads. In our case, the stiffeners should be placed above the discrete supports, see Fig. 2.



**Fig. 2.** Stiffening elements above discrete supports of the shell.

Here the question is, how tall could be these stiffeners? The reasonable approach is vertical stiffening elements to reach the level in which there is an equalization of the values of the meridional normal stresses above the supports and in the middle between supports. Under this level the cylindrical shell will be considered as a part of ring beam, stiffened by elements above the supports. Above it, cylinder can be modelled as continuously supported shell. But where is the position of this level? Values of critical height  $H_{cr}$  of the shell and ideal position  $H_I$  of intermediate stiffening ring are very different between

themselves. Furthermore, in his research Zdravkov (2017a) shows that when there are vertical stiffening elements without stiffening ring in the upper end, the height of the critical zone in which are distributed vertical reactions of discrete supports, is increased. In other words as longer are the stiffeners, as higher will be the critical zone. Therefore, there is a certain level, placement of stiffening elements over it is not only pointless, but even harmful. In the present article the author will try to determine the limits of this level.

## 2. Finite Element Analysis

For the purpose of research, three steel cylindrical shells are modelled, using software ANSYS. Their parameters are as follow:

a) dimensions:

- shell 1 – diameter  $D = 3$  m, height  $H = 6$  m;
- shell 2 – diameter  $D = 4$  m, height  $H = 8$  m;
- shell 3 – diameter  $D = 5$  m, height  $H = 10$  m.

b) all shells are with constant thickness  $t = 5$  mm.

c) all shells are supported by six immovable supports with dimensions in plane  $125 \times 125$  mm, see Fig. 3.

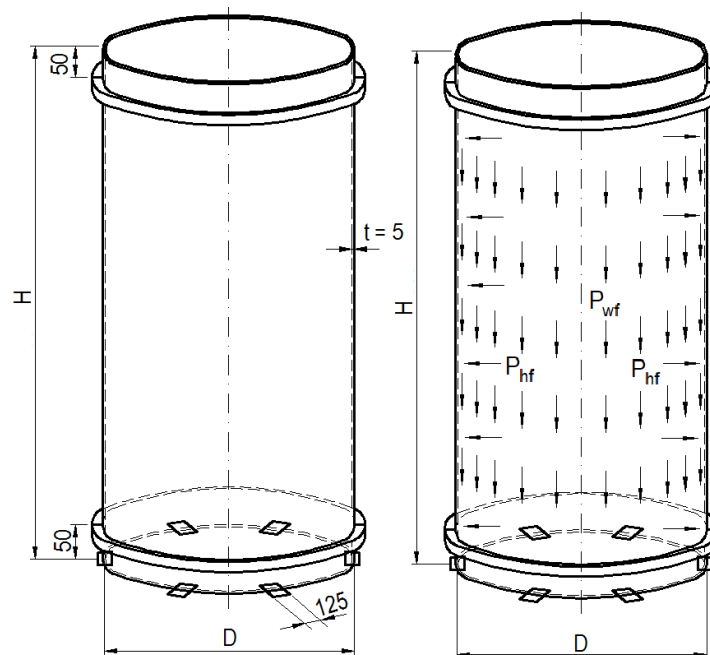

**Fig. 3.** Numerical models – dimensions and loading.

d) in order to strengthen the shells in radial direction, on 50mm above the lower edge and on 50mm below the upper edge are placed rings with section L100x8 mm, welded as is shown on Fig. 6 ;

e) the stored in the facilities product varies. For each shell it is as follow:

- shell 1 – cement;
- shell 2 – lime;
- shell 3 – sand.

Every product causes horizontal pressure  $P_{hf}$  and vertical  $P_{wf}$  load due to the friction between the stored material and the shell. Their values are determined for every particular product according to standard EN 1991-4. All loads are uniformly distributed and applied as a surface pressure on the shell. They are applied to internal surface of the shells.

f) shells 1, 2 and 3 are researched in six different types of the stiffening on the supports:

- models without stiffeners above the supports, see Fig. 4a;

- the shells are stiffened with an intermediate ring with section L100x8 mm, see Fig. 4b. Above every support are placed 2 steel plates with section 8x100 mm, which reach the intermediate ring.

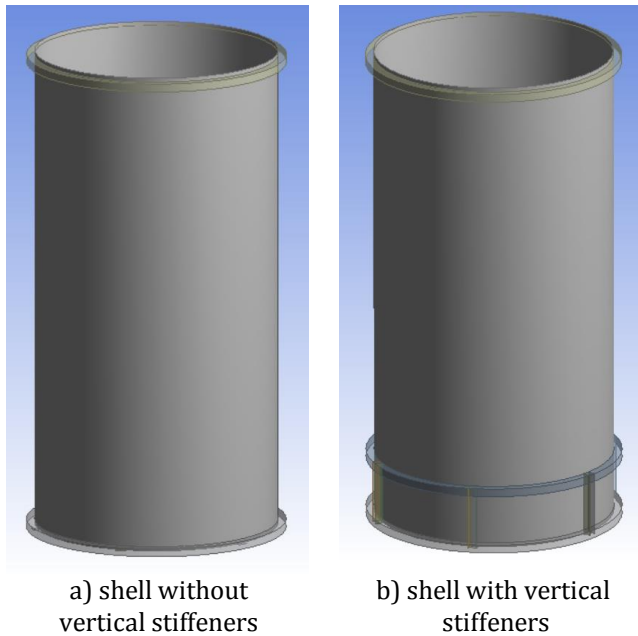
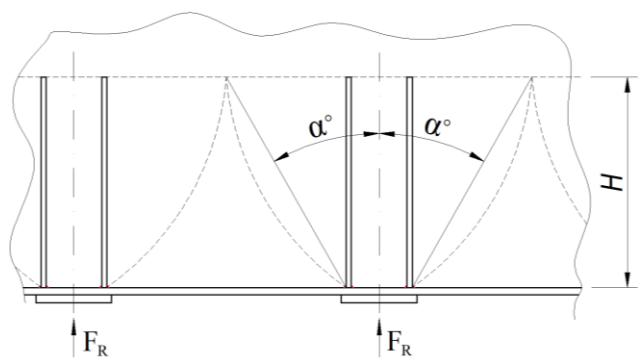

**Fig. 4.** Vertical stiffening elements on the cylindrical shell.

The levels of intermediate stiffening ring are calculated as follow:

- using an average value of distribution of discrete forces  $F_R$  from supports  $\alpha = 45^\circ$ , see Fig. 5. The height  $H_{45}$  is determined with the expression:

$$H_{45} = \frac{\pi R}{n} \tag{14}$$



**Fig. 5.** Average angle  $\alpha$  of distribution of the compressive forces on height.

- at ideal position of the intermediate stiffening ring on the shell. The height  $H_1$  will be calculated by the formula (12);

- using an average value of distribution of discrete forces  $F_R$  from supports  $\alpha = 30^\circ$ . The height  $H_{30}$  should be calculated by the formula:

$$H_{30} = \frac{\pi R}{n} \tan(90^\circ - \alpha^\circ), \tag{15}$$

- the length of the stiffeners  $H_L$  is equal to distance between the supports. It is calculated according to the formula:

$$H_L = \frac{2\pi R}{n}, \tag{1}$$

- the height of the stiffeners is equal to the critical height  $H_{cr}$  of the shell, which is calculated according to the formula (11).

g) material of elements is steel S235, with a properties according to European standard EN 10025-2:2004.

The angular section L100x8 and a part of the cylindrical shell form an intermediate stiffening ring with a shape as is shown on Fig. 6.

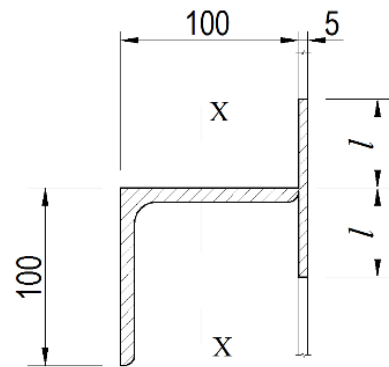

**Fig. 6.** Shape of the intermediate stiffening ring.

Effective width  $l$  of the steel sheets over and below the joint is calculated according to the standard API 650, by the expression:

$$l \leq 13.4\sqrt{Dt}, \tag{17}$$

where:  $D$  is a diameter of the cylindrical shell, m;  $t$  - thickness of the cylindrical shell, mm.

Effective width  $l$  for the shells with the smallest diameter,  $D = 3$  m, is  $l = 51.9$  mm. I accept to have effective width  $l = 50$  mm for all shells. It is on way of safety.

The geometric characteristics of the obtained stiffening ring are:

- a) area -  $A = 20.5 \text{ cm}^2$  ;
- b) moment of inertia about vertical axis "x-x" -  $I_x = 358.4 \text{ cm}^4$ .

For different shells, the ratio of the stiffness's  $\chi$ , calculated according to the formula (13), has the values as follow:

- shell 1 -  $\chi = 0.042$ ;
- shell 2 -  $\chi = 0.0764$ ;
- shell 3 -  $\chi = 0.130$ .

The maximum value of the ratio  $\chi = 0.130 < 0.2$ , so it could be expected that the stiffness of the intermediate ring will be sufficient to equalize the meridional stresses in the shell above it.

The shells are modeled by 2D quad elements "Shell 181" with maximum dimensions of 50 mm. The method of their creation is "All quad". Element's midside nodes are controlled by program.

Thin shell structures are sensitive for effect of changes of geometry during loading. On that reason geometrically nonlinear analyses (GNIA) are used, according to the recommendations of EN 1993-1-6.

ANSYS's option "symmetry" is activated to reduce a calculation time. In analysis is used a quarter of silo only.

Axial normal stresses are accounted by the height of shell, in the middle between two supports and above the supports. After that are determined the values of ratio  $\sigma_{x,m}/\sigma_{x,s}$ , where:

$\sigma_{x,m}$  is meridional normal stress by height of the cylinder, in the middle between two supports;

$\sigma_{x,s}$  - meridional normal stress by height, above the supports.

The idea is that where the ratio  $\sigma_{x,m}/\sigma_{x,s} = 1.0$ , is the upper border of the critical zone in the shell, in which are redistributed vertical reactions of supports. Above that border circumferential nonuniformity in the axial membrane stresses does not exist and the shell is continuously supported.

The study continues with a buckling analysis. This solution gives the load multiplier "k", which can be assumed as a reserve of the bearing capacity of the shell. The reserve k gives a quantity assessment of the influence of the different height of the vertical stiffeners on the bearing capacity of the shell.

### 3. Analysis Results

In the charts below, see Fig. 7, could be seen the accounted through numerical methods change in the ratio  $\sigma_{x,m}/\sigma_{x,s}$  by the height of the shell.

Obviously, the presence of an intermediate stiffening ring above the supports is favourable. It limits the inequality of the meridional stresses above it.

The Fig. 7 shows ratios  $\sigma_{x,m}/\sigma_{x,s} > 1.0$ . It means that in part of the shell the axial stresses in the middle between the supports are bigger than the stresses above the supports. A similar phenomenon has been observed in previous researches of Zdravkov (2017a, 2017b). This effect is underlined in shells without intermediate rings, in which could be reported values of the ratio  $\sigma_{x,m}/\sigma_{x,s} > 2.0$ .

It could be seen that as longer are the vertical stiffening elements as bigger are the ratios  $\sigma_{x,m}/\sigma_{x,s}$  above their upper end, i.e. the inequality of the stresses above them is smaller. Exceptions here are the stiffening elements with height  $h = H_{cr}$ .

The results of the performed Buckling Analysis for each of shells are as follows:

#### a) shell 1

- there are no vertical stiffeners -  $k = 8.809$ ;
- $H_{45} = 785$  mm -  $k = 26.392$ ;
- $H_1 = 1185$  mm -  $k = 29.789$ ;
- $H_{30} = 1360$  mm -  $k = 30.767$ ;
- $H_L = 1571$  mm -  $k = 31.527$ ;
- $H_{cr} = 2890$  mm -  $k = 32.072$ .

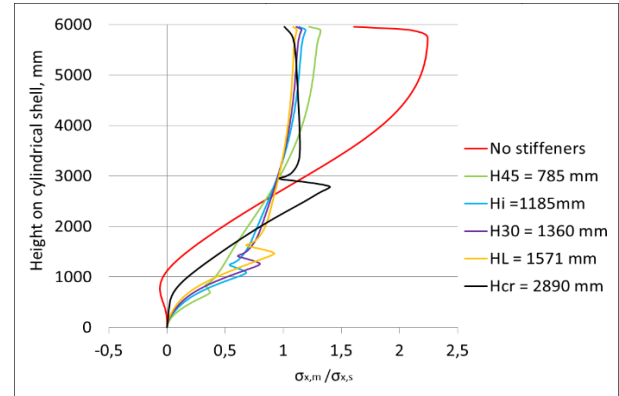

a) shell 1 - diameter  $D = 3$  m, height  $H = 6$  m

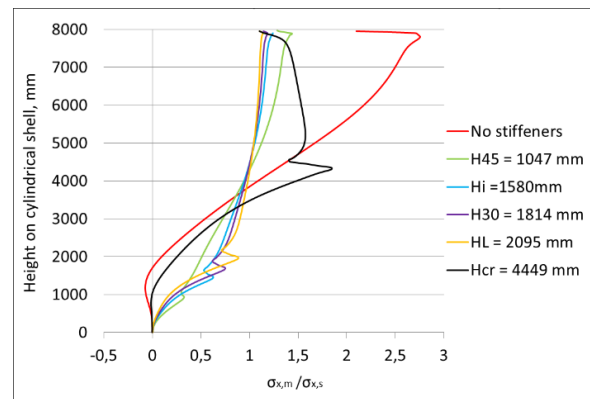

b) shell 2 - diameter  $D = 4$  m, height  $H = 8$  m

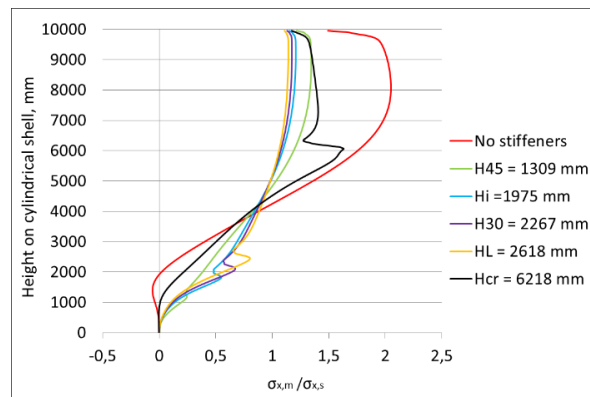

c) shell 3 - diameter  $D = 5$  m, height  $H = 10$  m

**Fig. 7.** Change of ratio  $\sigma_{x,m}/\sigma_{x,s}$  by the height of the cylindrical shell.

#### b) shell 2

- there are no vertical stiffeners -  $k = 5.719$ ;
- $H_{45} = 1047$  mm -  $k = 19.478$ ;
- $H_1 = 1580$  mm -  $k = 21.872$ ;
- $H_{30} = 1814$  mm -  $k = 22.387$ ;
- $H_L = 2095$  mm -  $k = 22.731$ ;
- $H_{cr} = 4449$  mm -  $k = 22.474$ .

#### c) shell 3

- there are no vertical stiffeners -  $k = 1.571$ ;
- $H_{45} = 1309$  mm -  $k = 3.293$ ;
- $H_1 = 1975$  mm -  $k = 3.548$ ;
- $H_{30} = 2267$  mm -  $k = 3.622$ ;
- $H_L = 2618$  mm -  $k = 3.688$ ;
- $H_{cr} = 6218$  mm -  $k = 3.835$ .

It is obvious that the using of vertical stiffening elements considerably increase bearing capacity of the shell on meridional loading. Longer stiffeners assure bigger reserve of bearing capacity. The effect is not linear and decrease with elongation of stiffeners. Therefore, the author would recommend the use of the vertical stiffening elements with length  $H_1 \leq h \leq H_L$ .

When the researched shells do not have vertical stiffeners, loss of stability is caused by the axial stresses  $\sigma_{x,s}$ . The buckled zone is just above the supports, see Fig. 8a. When the shells have vertical stiffening elements and a horizontal ring above them, the loss of stability is caused by shear stresses. The zone of buckling is on both sides of the vertical stiffeners, see Fig. 8b.

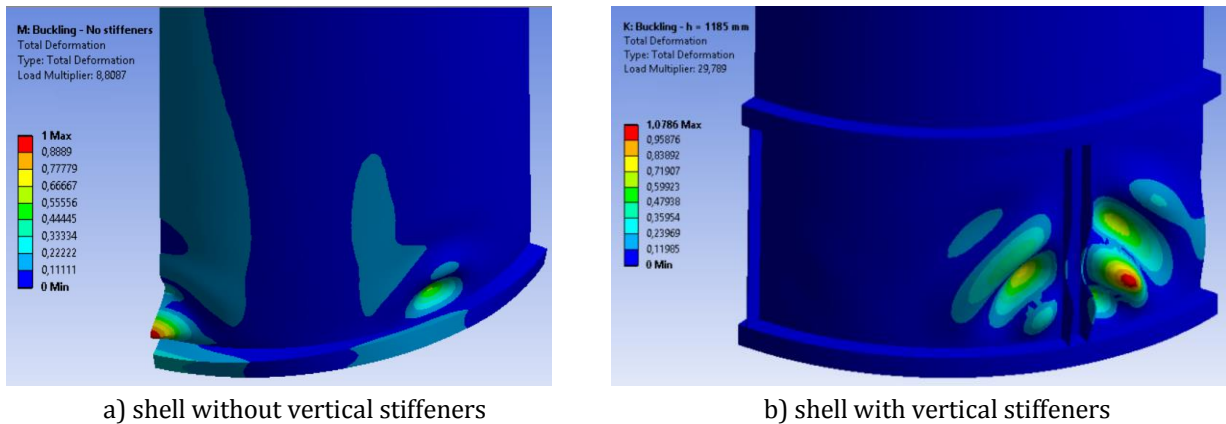

Fig. 8. Modes of buckling of the cylindrical shell.

#### 4. Conclusions

Common practice in design of steel silos is to place stiffening elements in applying point of concentrated loads. In our case the stiffeners are placed above the discrete supports. As a result, bearing capacity of the shell on meridional loads increases. Longer stiffeners assure bigger bearing capacity, but the effect decreases with elongation of stiffeners.

In his researches, Zdravkov (2017a, 2107b, 2018) shows that equalizing of the axial normal stresses on the height depends on a lot of factors. As a presence, by vertical stiffeners and/or intermediate rings, value of internal pressure, ratio  $D/t$  and other. On that reason the author cannot state exactly how long should be the stiffening elements. As a conclusion of this research can recommend the limits of the length  $h$  of the stiffeners. According to the author, it should be  $H_1 \leq h \leq H_L$ . When the height  $h \leq H_1$ , ratio  $\sigma_{x,m}/\sigma_{x,s} < 0.6$ , in other words there is a large inequality in the meridional normal stresses above the upper end of the stiffeners. There is no much sense to use stiffeners with a length  $h > H_L$ , because the effect of their elongation above these values is too small. Beside of it the longer stiffening elements lead to ratio  $\sigma_{x,m}/\sigma_{x,s} > 1.0$  in their upper end.

#### REFERENCES

- ANSYS 17 (2016). Ansys Inc. Canonsburg, PA, USA.
- API Standard 650 (2013). Welded Tanks for Oil Storage. Twelfth Edition, American Petroleum institute.
- Calladine CR (1983). Theory of Shell Structures. Cambridge University Press, Cambridge, U.K.
- EN 1991-4:2006 (2006). Actions on structures - Part 4: Silos and tanks, European committee for standardization, Brussels.
- EN 1993-1-6:2007 (2007). Design of steel structures - Part 1-6: Strength and Stability of Shell Structures, European committee for standardization, Brussels.
- EN 1993-4-1:2007 (2007). Design of steel structures - Part 4-1: Silos, European committee for standardization, Brussels.
- EN 10025-2:2004 (2004). Hot rolled products of structural steels - Part 2: Technical delivery conditions for non-alloy structural steels.
- Rotter JM (1985). Analysis and design of ringbeams. *Design of Steel Bins for Storage of Bulk Solids*, J. M. Rotter, ed., University of Sydney, Sydney, Australia, 164-183.
- Topkaya C, Rotter JM (2011a). Ring beam stiffness criterion for column supported metal silos. *ASCE Journal of Engineering Mechanics*, 134, 846-853.
- Topkaya C, Rotter JM (2011b). Stiffness of silo supporting ring beams resting on discrete supports. *6th International Conference on Thin-Walled Structures*, Timisoara, Romania.
- Topkaya C, Rotter JM (2014). Ideal location of intermediate ring stiffeners on discretely supported cylindrical shells. *Journal of Engineering Mechanics*, 140(4), 04013001.
- Vlasov VZ (1961). Thin-walled Elastic Beams. National Science Foundation, Washington, DC.
- Vlasov VZ (1964). General Theory of Shells and Its Applications in Engineering. NASA Technical Translation, TTF-99, Washington, DC.
- Zeybek Ö, Topkaya C, Rotter JM (2015). Strength and stiffness requirements for intermediate ring stiffeners on discretely cylindrical shells. *Thin-Walled structures*, 96, 64-74.
- Zeybek Ö, Topkaya C, Rotter JM (2017). Requirements for intermediate ring stiffeners placed below the ideal location on discretely supported shells. *Thin-Walled structures*, 115, 21-33.
- Zdravkov LA (2017a). Vertical stiffeners and internal pressure - influencing factors on distribution of meridional stresses in steel silos on discrete supports. *Challenge Journal of Structural Mechanics*, 3(3), 123-128.
- Zdravkov LA (2017b). Influence of intermediate rings and height of skirt on effective width of compression zone in junction column - cylindrical shell of steel silo. *International Jubilee Scientific Conference "75th Anniversary of UACEG"*, Sofia.
- Zdravkov LA (2018). Influencing factors on effective width of compressed zone in joint column - cylindrical shell of steel silo. *Challenge Journal of Structural Mechanics*, 4(1), 1-8.