



Vertical stiffeners and internal pressure - influencing factors on distribution of meridional stresses in steel silos on discrete supports

Lyubomir A. Zdravkov*

Department of Metal, Wood and Plastic Structures, University of Architecture, Civil Engineering and Geodesy (UACEG), Sofia 1046, Bulgaria

ABSTRACT

Steel silos are interesting, complicated facilities. In order to ensure unloading of whole amount of stored product by gravity, they are often placed on supporting structure. Values of stresses in joints between thin sheets and supporting frame elements are very high, which could cause local loss of stability in thin shells. Many researchers have worked on values and distribution of the meridional stresses in that joints. Their traditional approach is to divide in their minds cylindrical shell on two parts - discretely supported ring beam and continuously supported shell above it. As a result of their efforts critical height of shell H_{cr} and ideal position of intermediate stiffening ring on shell are determined. The scientific results are based on semi-membrane theory of Vlasov, in which influence of vertical stiffeners and internal pressure is not accounted. On other hand all steel silos are loaded with an internal pressure and majority of them have vertical stiffeners above supports. Is it possible the obtained scientific results to be applied to these silos? In a present article the author will show that stiffeners and pressure should not be ignored in analysis.

ARTICLE INFO

Article history:

Received 20 June 2017

Revised 15 August 2017

Accepted 25 August 2017

Keywords:

Steel silo

Meridional stresses

Critical height

Vertical stiffeners

Internal pressure

1. Introduction

Often steel silos are elevated facilities, put on supporting structure. The purpose is easily and completely unloading of all stored product by gravity. The supporting structure is different for every project, depending on real conditions of exploitation. The most popular are two types - built from horizontal girders and columns or from columns only. Both types of frame structure cause concentrated meridional forces in the cylindrical body of the silo. As a result, the thin shell could loses local stability.

The simplest way to design steel silos is to divide in our minds cylindrical shell on two parts - discretely supported ring beam and continuously supported shell above it. Obviously, to ensure continuously support of shell, bending stiffness of ring beam should be high. In European standard EN 1993-4-1 that concept is recognized but it keeps silence about recommended stiffness of ring beam. Rotter (1985) suggested that a value of ratio $\psi = 0,25$ might be suitable for adoption in design, where:

$$\psi = \frac{K_{\text{shell}}}{K_{\text{ring}}}, \quad (1)$$

in which K_{shell} is stiffness of cylindrical shell; K_{ring} is stiffness of ring beam.

Based on English translation of differential equations of curved beam of Vlasov (1961), stiffness of ring beam K_{ring} is expressed as:

$$K_{\text{ring}} = \frac{(n^2 - 1)^2 EI_r}{R^4} \cdot \frac{1}{f_r}, \quad (2)$$

where n is number of uniformly spaced supports; E is modulus of elasticity; I_r is moment of inertia about a radial axis; R is radius of ring beam centroid.

$$f_r = 1 + \frac{EI_r}{n^2 K_T}, \quad (3)$$

* Corresponding author. Tel.: +359-885-081-305 ; E-mail address: zdravkov_fce@uacg.bg (L. A. Zdravkov)

in which:

$$K_T = GJ + n^2 \frac{EC_w}{R^2}, \quad (4)$$

where G is shear modulus; J is uniform torsion constant; C_w is warping constant for an open sections.

Semi-membrane theory of shells, proposed by Vlasov (1964), gives expression of stiffness of cylindrical shell, as following:

$$K_{shell} = n\sqrt{(n^2 - 1)} \frac{E}{\sqrt[4]{3}} \left(\frac{t}{R}\right)^{3/2} \cdot \frac{1}{f_s}, \quad (5)$$

where t is thickness of cylindrical shell.

$$f_s = \frac{(e^\eta)^2 - 2 \cdot e^\eta \cdot \sin(\eta) - 1}{(e^\eta)^2 - 2 \cdot e^\eta \cdot \cos(\eta) + 1}, \quad (6)$$

in which:

$$\eta = \frac{2\pi H}{\mu}, \quad (7)$$

where H is height of cylindrical shell; μ is expressed by Calladine (1983) long wave bending half-wavelength:

$$\mu = \frac{2\pi^4 \sqrt[4]{3}}{n\sqrt{(n^2 - 1)}} \sqrt{\frac{R}{t}} \cdot R. \quad (8)$$

Based on Eqs. (2) and (5), stiffness ratio ψ will look like as:

$$\psi = \frac{K_{shell}}{K_{ring}} = \frac{0.76(Rt)^2}{I_r} \sqrt{\frac{R}{t}} \sqrt{\frac{n^2}{(n^2 - 1)^3}} \cdot \frac{f_r}{f_s}. \quad (9)$$

For simplification, Eq. (6) could be represented by two simple relations:

$$f_s = \begin{cases} \frac{\eta}{3}, & \text{when } H \leq H_{cr} \\ 1.0, & \text{when } H > H_{cr} \end{cases}, \quad (10)$$

where H_{cr} is critical height of cylindrical shell. It could be determined by formulae:

$$H_{cr} = \frac{3^4 \sqrt[4]{3}}{n\sqrt{(n^2 - 1)}} \sqrt{\frac{R}{t}} \cdot R. \quad (11)$$

H_{cr} represents height of shell which is effective of redistributing of discrete forces from supports. When height of shell $H \leq H_{cr}$, entire shell resists axial loads from supports. When $H > H_{cr}$, only that part between bottom of shell and critical height H_{cr} is effective in redistributing of vertical reactions from discrete supports.

In his research of Topkaya and Rotter (2011a; 2011b) conducted extensive finite element analyses for verification of Rotter's criterion about stiffness of ring beam. With 1280 separate finite-element analyses (FEA), covering two different types of ring sections, various heights and radii of cylindrical shells, the authors checked validity of suggested by Rotter (1985) ratio $\psi = 0,25$. On basis of done FEA they concluded, when a stiffness ratio $\psi \leq 0,1$, axial stresses will not deviate more than 25 % from the uniform support assumption.

Later Topkaya and Rotter (2014) determined ideal location of intermediate stiffening rings on the shell. They expect a ring, placed at this ideal position, can effectively remove all circumferential non-uniformity in the axial membrane stress above it. The simple expression of ideal height H_1 is:

$$H_1 = \sqrt{12(1+\nu)} \frac{R}{n}, \quad (12)$$

where ν is Poisson's ratio.

Eq. (12) is verified by the authors using a total of 2400 finite element analyses.

Necessary stiffness of intermediate stiffening rings is determined by Zeybek et al. (2015). Stiffness ratio χ could be expressed as:

$$\chi = \frac{K_{shell}}{K_{stiffener}} = \frac{Rt(AR^2 + I_x^2(n^2 - 1))}{12\sqrt[4]{3}(1+\nu)^{1,5} \cdot AI_x n(n^2 - 1)^2}, \quad (13)$$

where K_{shell} is circumferential stiffness of the shell; $K_{stiffener}$ is circumferential stiffness of circular ring; A is cross sectional area of the stiffening ring; I_x is moment of inertia of the stiffening ring about vertical axis "x-x".

The results in the research of Zeybek et al. (2015) indicate that ratios below about $\chi < 0.2$ provide a satisfactorily uniform axial membrane stress distribution above the intermediate ring stiffener, so this limit is recommended for practical design.

Common practice in design of real steel structures is to put stiffeners in point of application of concentrated loads. In our case, stiffeners should be positioned above discrete supports, see Fig. 1.



Fig. 1. Stiffeners in discrete supports of shell.

Additionally, all steel silos are storage facilities, loaded by radial internal pressure due to stored product. This is inevitable.

In all quoted researches above, in all equations, in all numerical models, influence of stiffeners and internal

pressure is missing. Which means that all their formulas are correct for smooth shells, axially loaded only. What about the other silos?

The author will try to check whether presence of vertical stiffeners and internal pressure has a substantially influence on distribution of meridional stresses and critical height of shell.

2. Analysis

For the purpose of analysis, a real steel silo in service will be used. Its parameters are as follow:

- a) capacity - $V = 110 \text{ m}^3$;
- b) diameter - $D = 3485 \text{ mm}$;
- c) height of cylindrical shell - $H_s = 10950 \text{ mm}$;
- d) five courses, with thickness - $t_{s,1} = 7 \text{ mm}$, $t_{s,2} = 6 \text{ mm}$, $t_{s,3} = t_{s,4} = t_{s,5} = 4 \text{ mm}$;

- e) thickness of conical hopper - $t_h = 5 \text{ mm}$;
- f) stored product - lime.

Hopper is jointed to shell above bottom of first course, i.e. silo has a skirt. Angle section L100x10 is welded on opposite side of joint, see Fig. 2. Researched models of steel silos have two heights of skirt h_{sk} :

- a) $h_{sk} = 500 \text{ mm}$ for Silo 1, Silo 2, Silo 3, Silo 4, Silo 5 and Silo 6;
- b) $h_{sk} = 860 \text{ mm}$ for Silo 7, Silo 8, Silo 9, Silo 10, Silo 11 and Silo 12.

The second used height $h_{sk} = 860 \text{ mm}$ corresponds with Eq. (12) about ideal location of intermediate stiffening rings:

$$H_1 = \sqrt{12(1+\nu)} \frac{R}{n} = \sqrt{12(1+0.3)} \frac{1742.5}{8} = 860 \text{ mm}$$

On the top of shell is put another angle L100x10.

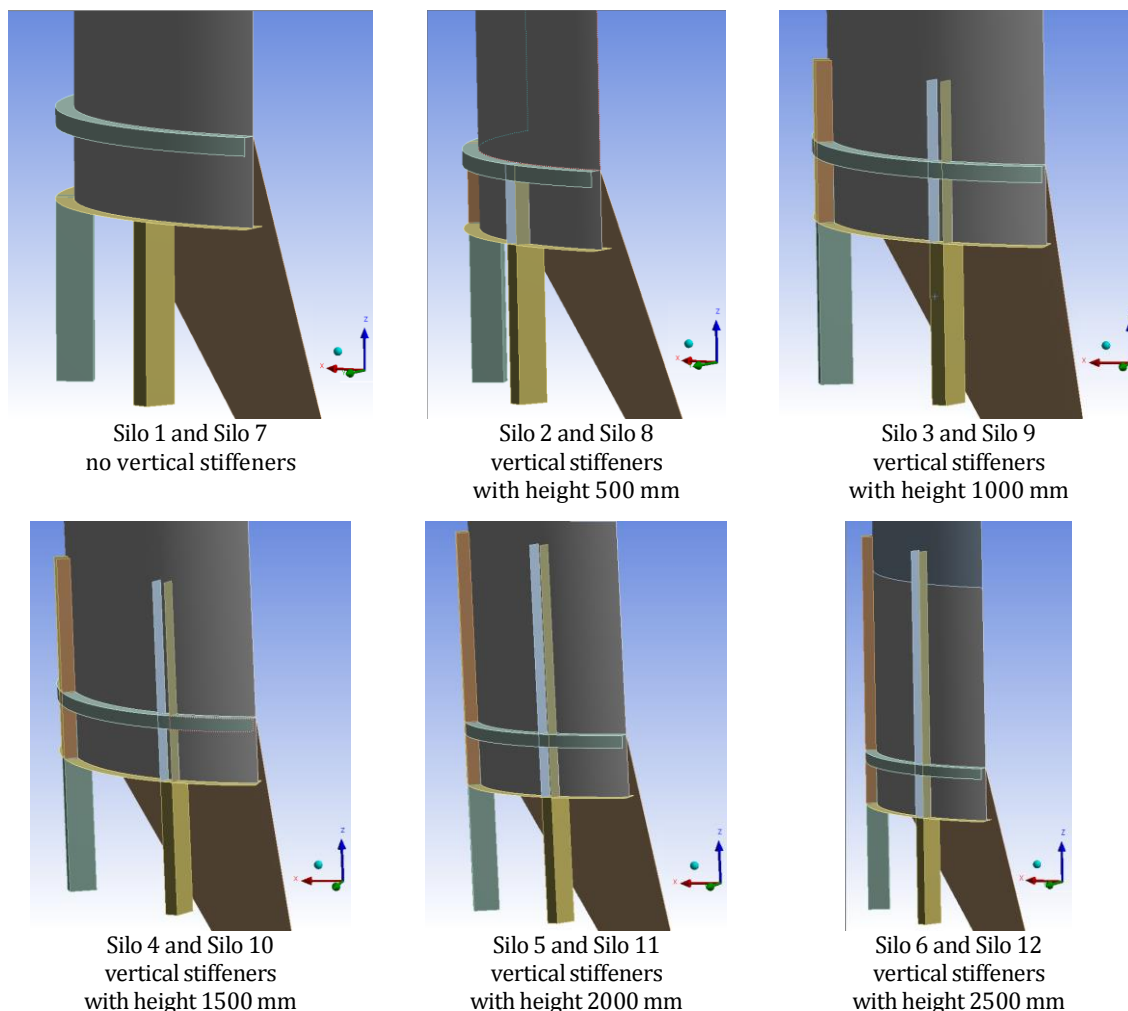

Fig. 2. Vertical stiffeners on cylindrical shell.

No circular stiffener on top of the longer vertical stiffeners, see Fig. 2. No additional intermediate stiffening rings on the shell.

Under the skirt of silo are situated 8 columns with rectangular hollow section 200x100x8 mm. Bigger dimension of section is in radial direction, smaller - in circumferential. Height of all columns is 1000 mm. They are

fixed to the ground (foundations). All elements are done by steel S235, with a properties according to European standard EN 10025-2:2004. First shell course, conical hopper and angle section L100x10 form stiffening ring as is shown on Fig. 3. It is accepted effective width of steel plates to be $16.t_i$ up and below the joint, according to standards API 650 and EN 14015.

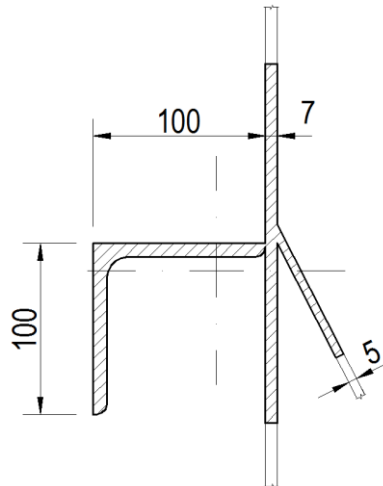

Fig. 3. Joint of hopper to cylindrical shell.

Geometrical characteristics of stiffening ring are:

- a) area - $A = 35.19 \text{ cm}^2$;
 - b) moment of inertia about vertical axis - $I_x = 727.4 \text{ cm}^4$.
- Stiffness ratio χ according to Eq. (13) is:

$$\chi = \frac{Rt(AR^2 + I_x n^2 (n^2 - 1))}{12\sqrt{3}(1 + \nu)^{1.5} \cdot A I_x n (n^2 - 1)^2}$$

$$= \frac{174,25 \cdot 0,7 \cdot (35,19 \cdot 174,25^2 + 727,4 \cdot 8^2 \cdot (8^2 - 1))}{12 \cdot \sqrt{3} \cdot (1 + 0,3)^{1,5} \cdot 35,19 \cdot 727,4 \cdot 8 \cdot (8^2 - 1)^2}$$

$$= 0.0195$$

Accounted ratio $\chi = 0.0195 < 0.2$, so stiffness should be enough for equal distribution of meridional stresses above the ring.

Using analytical software ANSYS are researched twelve models of silos, see Fig. 3. Differences between them are:

- a) two heights of skirt h_{sk} , as is written above;
- b) presence and height of vertical stiffening plates with section 8x100 mm.

For modelling of silos is used 2D element shell181. Quadrilateral method for meshing is used. Free face mesh method is "All quad". Max face size is 50 mm. Element's midside nodes are controlled by program.

ANSYS's option "symmetry" is activated to reduce a calculation time. In analysis is used a quarter of silo only.

Thin shell structures are sensitive for effect of changes of geometry during loading. On that reason geometrically nonlinear analyses (GNIA), described in EN 1993-1-6, were conducted.

On a first step, all silos are loaded by meridional (axial) force with value $F = 800 \text{ kN}$, applied to upper edge of cylindrical shell as equal distributed load. The force F is applied on the top of shell to discover where meridional compressive stresses σ_x going to be equal to uniform meridional stresses $\sigma_{x,m}$. Where ratio reaches value $\sigma_x/\sigma_{x,m}=1.0$ is upper border of critical zone in shell, which redistributes vertical reactions from discrete supports.

On the second step, to meridional force F is added internal pressure as following:

- a) on cylindrical shell - normal pressure $p_n = 35 \text{ kPa}$;
- b) on conical hopper:
 - normal pressure - $p_n = 35 \text{ kPa}$;
 - tangential distributed load - $p_t = 15,16 \text{ kPa}$.

Vertical force F and internal pressure are calculated for the real stored product (lime), according to standard EN 1991-4.

3. Results

In charts below, see Figs. 4 and 5, could be seen accounted by FEA change of ratio $\sigma_x/\sigma_{x,m}$ by height of shell, where: σ_x is meridional compressive stress by height of the cylinder; $\sigma_{x,m}=F/A$ is equal (uniform) meridional compressive stress, in which: F is the axial force, applied on the top of shell; A is the area section of cylindrical shell.

To ignore secondary stresses due to local effect of stiffening plates, meridional compressive stresses σ_x are measured in the middle between supports.

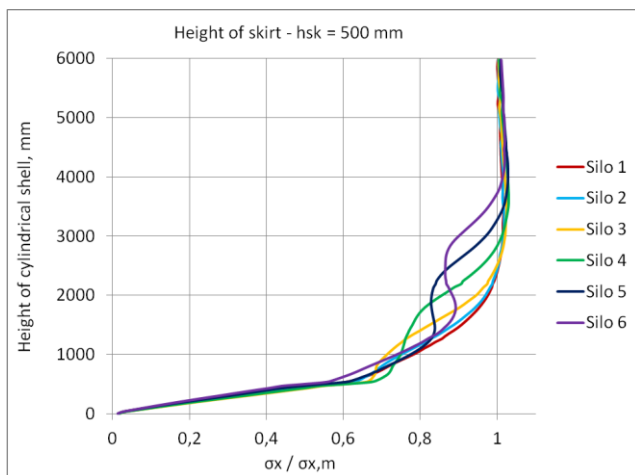

a) internal pressure is $p = 0$
(first step of loading)

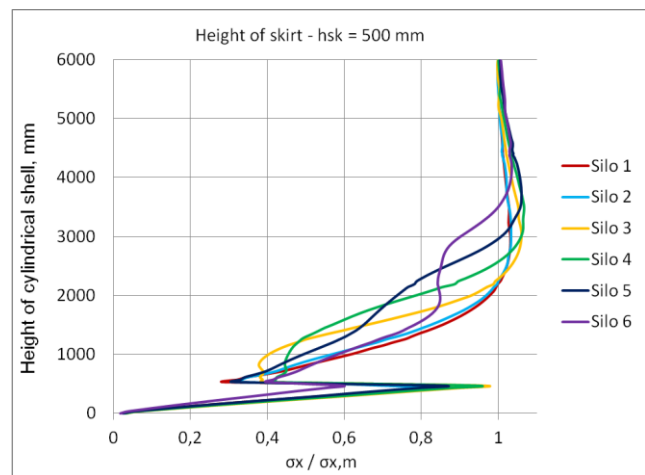

b) internal pressure is $p \neq 0$
(secondary step of loading)

Fig. 4. Change of ratio $\sigma_x/\sigma_{x,m}$ by height of shell (height of skirt $h_{sk}=500 \text{ mm}$).

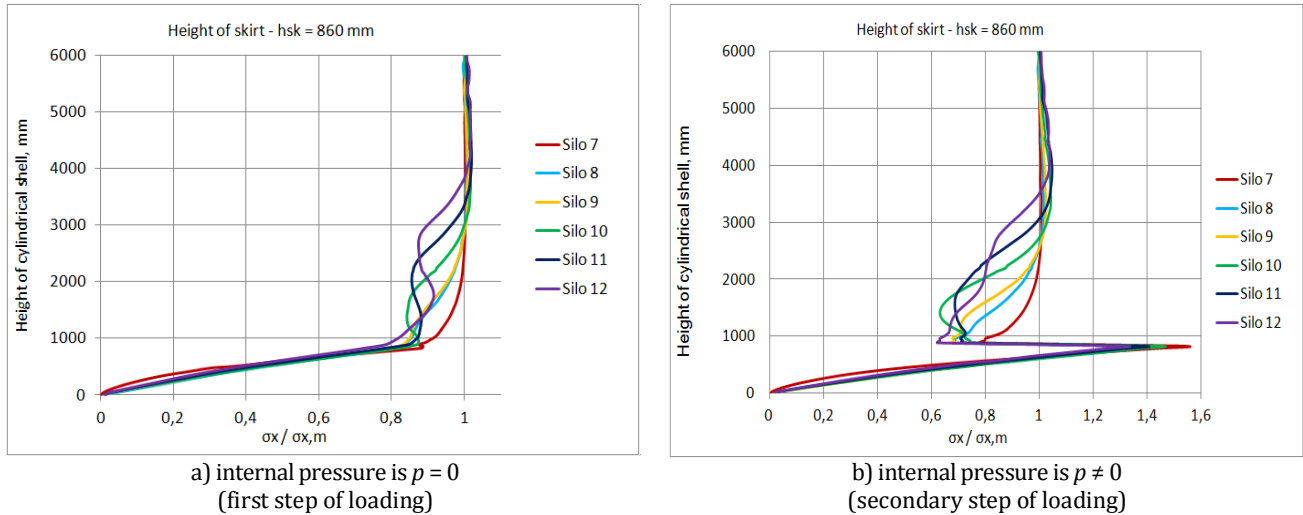

Fig. 5. Change of ratio $\sigma_x/\sigma_{x,m}$ by height of shell (height of skirt $h_{sk}=860$ mm).

Value of critical height of shell H_{cr} should be calculated by Eq. (11):

$$H_{cr} = \frac{3\sqrt[4]{3}}{n\sqrt{(n^2-1)}} \sqrt{\left(\frac{R}{t}\right)} \cdot R$$

$$= \frac{3\sqrt[4]{3}}{8\sqrt{(8^2-1)}} \sqrt{\left(\frac{1742.5}{7}\right)} \cdot 1742.5 = 1709 \text{ mm}$$

Accounted by FEA lowest height, necessary to equalize values of σ_x and $\sigma_{x,m}$, refers to silos without vertical stiffeners. It is approximately $H=2300$ mm. Obviously it is higher than calculated by Eq. (11), but ratio $\sigma_x/\sigma_{x,m}=0.94$ on height $H=1709$ mm, i.e. difference is less than 25%.

Vertical stiffeners above supports increase critical zone in shell, which redistributes vertical reactions from discrete supports. For example, in silo 6 ratio $\sigma_x/\sigma_{x,m}=1.0$ on height $H=3733$ mm.

Internal pressure decreases with a little height of critical zone of shell. More important is its influence on change of forces/stresses below and above the joint with the hopper. In silos with high positioned hoppers, values of meridional normal stresses σ_x in skirt may exceed equal stress $\sigma_{x,m}$, see Fig 5(b).

On Fig. 4 and Fig. 5 could be seen ratios $\sigma_x/\sigma_{x,m}>1.0$. It means that in part of the shell, meridional stresses in the middle, between supports, are bigger than meridional stresses above supports, see Fig. 6. A similar phenomenon has also been reported in a study of Knödel and Um-menhofer (2009).

Various height of skirt do not change critical height of shell. On other hand, placed on ideal position intermediate stiffening ring limits irregularity of meridional stresses above critical height.

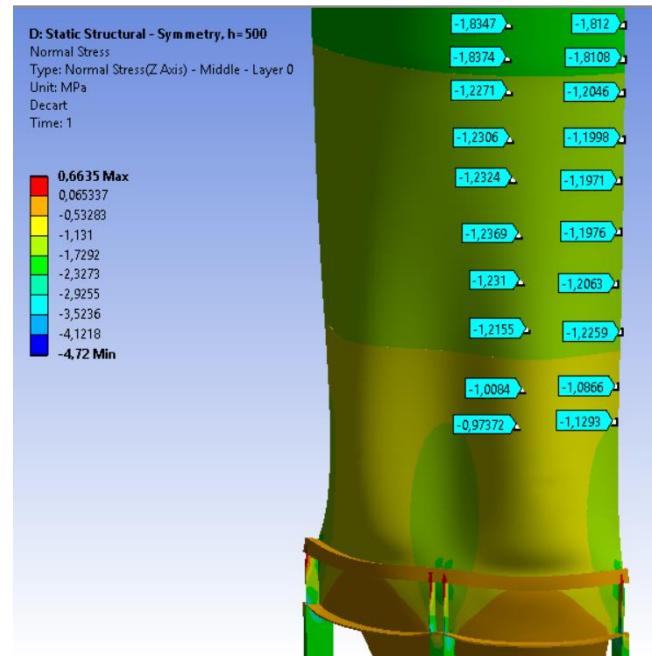

Fig. 6. Change of meridional normal stresses σ_x .

4. Conclusions

Real steel silos in service are loaded by radial internal pressure due to stored product. In addition, common practice in structural design is to put stiffeners in point of application of concentrated loads. In our case stiffeners should be positioned above discrete supports. In earliest researches about critical height of shell and ideal position of intermediate stiffening ring, influence of vertical stiffeners and internal pressure is not taken into account. In present article is verified whether they effect on height of critical zone in shell.

The main outcomes from the current research are:

- In space between bottom of first course and joint shell - hopper, presence or not of vertical stiffeners do not change meridional stresses σ_x ;
- Vertical stiffeners, especially these with big length above horizontal joint silo - hopper, could change significantly ratio $\sigma_x/\sigma_{x,m}$;
- Presence of vertical stiffeners without stiffening ring on their top increase height of critical zone, which redistributes vertical reactions from discrete supports;
- Internal pressure, due to stored product, decreases with a little height of critical zone of shell. More important is its influence on change of stresses below and above the joint with the hopper;
- There are some parts of cylindrical shell, where meridional normal stresses above supports are smaller than these between supports.

REFERENCES

- ANSYS, Release 17 (2016). ANSYS, Inc., Canonsburg, PA, USA.
- API Standard 650 (2013). Welded Tanks for Oil Storage. Twelfth Edition. American Petroleum Institute, Washington, DC.
- Calladine CR (1983). Theory of Shell Structures. Cambridge University Press, Cambridge, U.K.
- EN 1991-4:2006 (2006). Eurocode 1 - Actions on structures - Part 4: Silos and tanks. European Committee for Standardization, Brussels.
- EN 1993-1-6:2007 (2007). Design of steel structures - Part 1-6: Strength and Stability of Shell Structures. European Committee for Standardization, Brussels.
- EN 1993-4-1:2007 (2007). Design of steel structures - Part 4-1: Silos. European Committee for Standardization, Brussels.
- EN 10025-2:2004 (2004). Hot rolled products of structural steels - Part 2: Technical delivery conditions for non-alloy structural steels. European Committee for Standardization, Brussels.
- EN 14015:2004 (2004). Specification for the Design and manufacture of site built, vertical, cylindrical, flat-bottomed, above ground, welded, steel tanks for the storage of liquids at ambient temperature and above. European Committee for Standardization, Brussels.
- Knödel P, Ummerhofer T (2009). Silos with stepped wall thickness on local supports. *Proceedings of the International Association for Shell and Spatial Structures (IASS) Symposium*, Valencia.
- Rotter JM (1985). Analysis and Design of Ringbeams. In: *Design of Steel Bins for Storage of Bulk Solids*, J. M. Rotter, ed., University of Sydney, Sydney, Australia, 164–183.
- Topkaya C, Rotter JM (2011a). Ring beam stiffness criterion for column supported metal silos. *ASCE Journal of Engineering Mechanics*, 134, 846-853.
- Topkaya C, Rotter JM (2011b). Stiffness of silo supporting ring beams resting on discrete supports. *6th International Conference on Thin-Walled Structures*, Timisoara, Romania.
- Topkaya C, Rotter JM (2014). Ideal location of intermediate ring stiffeners on discretely supported cylindrical shells. *Journal of Engineering Mechanics*, 140(4), 04013001.
- Vlasov VZ (1961). Thin-walled elastic beams. National Science Foundation, Washington, DC.
- Vlasov VZ (1964). General theory of shells and its applications in engineering. NASA Technical Translation, TTF-99, Washington, DC.
- Zeybek Ö, Topkaya C, Rotter JM (2015). Strength and stiffness requirements for intermediate ring stiffeners on discretely cylindrical shells. *Thin-Walled Structures*, 96, 64-74.