

---

# Study of Sorptivity of Self-Compacting Concrete with Different Chemical Admixtures

Alsheikh S.A.<sup>1</sup>

Department of Civil Engineering,  
Modern University, Cairo, Egypt

---

## Abstract

The influence of chemical admixtures on the properties of Self-Compacting Concrete (SCC) was investigated. All types of used admixtures were the same percentage of 1.4% according technical data. The water – cement ratio was maintained at 0.36 for all mixes. The paper presents test results for acceptance characteristics of flowability, resistance against segregation, and passing ability of self-compacting concrete in fresh state. Further, mechanical properties of hardened concrete such as compressive, tensile and flexural strength at the ages of 7 and 28 were also determined, and results of Absorption and sorptivity result are included here. The results indicate that SikaViscoCrete3425 and AddiCrete BVS 100 give better results for all tests.

*Keywords: Self-compacting concrete; Sorptivity; Absorption; Durability; Superplasticizer.*

---

## 1. Introduction

Self-Compacting Concrete (SCC) not only increases the reliability of structures but also reduces the number of workers required at the construction site and streamlines the construction. In pre-cast product plants as well, Self-Compacting Concrete is highly effective in reducing the noise as it requires no vibration[1]. SCC is a highly flowable, yet stable concrete that can spread readily into place and fill the formwork without any consolidation and without undergoing any significant separation. In general, SCC results in reduced construction times and reduced noise pollution [2].

SCC is defined as concrete that is able to flow and consolidate under its own weight, completely fill the formwork even in the presence of dense reinforcement, whilst maintaining homogeneity and without the need for any additional compaction [3]. Superplasticizer enhances deformability and with the reduction of water/powder segregation resistance is increased [4][5].

---

<sup>1</sup>E-mail:saeedalsheikh56@yahoo.com

Sorptivity, which is an index of moisture transport into unsaturated specimens, has been recognised as an important index of concrete durability, because the test method used for its determination reflects the way that most concretes will be penetrated by water and other injurious agents and it is an especially good measure of the quality of near surface concrete, which governs durability related to reinforcement corrosion [6]. The sorptivity coefficient is essential to predict the service life of concrete as a structural and to improve its performance [7]. It was reported that the sorptivity of air-cured fly ash concrete, cured for 28, 90 and 180 days, increases with increase in fly ash content. In normal concrete has been shown that the condensed silica fume, under normal curing environments, to both increase strength and reduce sorptivity [8].

**2. Experimental investigation**

**2.1 Properties of materials**

**2.1.1 Ordinary Portland cement (O.P.C)**

Ordinary Portland cement (CEM I 42.5N) was used. Its typical physical properties and chemical analysis are shown in Table 1. The cement content was 500 kg/m<sup>3</sup>.

Table 1: Properties of Used Portland Cement

Description	Value
Physical Properties	
1- Specific gravity	3.15
2- Fineness passing 90 µm%	93%
3- Surface area cm <sup>2</sup> /gm	3315
Chemical Analysis	
1- Lime Calcium Oxide (CaO)	60 : 67 %
2- Silicon Dioxide (SiO <sub>2</sub> )	17 : 25 %
3- Aluminum Oxide (Al <sub>2</sub> O <sub>3</sub> )	3.0 : 8.0 %
4- Calcium Sulphate (CaSO <sub>4</sub> )	0.50 : 6.0 %
5- Magnesium Oxide (MgO)	0.10 : 4.0 %
6- Sulphur trioxide (SO <sub>3</sub> )	2.75 %
7- Alkalis	0.40 : 1.25 %
8- Loss in ignition %	3 %
Compressive Strength (Cubes)	
1- Age 2 days MPa	20.2
2- Age 7 days MPa	32.9
3- Age 28 days MPa	44.7

**2.1.2 Fine Aggregates**

Natural sand with medium size was used as a fine aggregate. Its physical properties were tested as specific gravity of 2.65 t/m<sup>3</sup>, fineness modulus of 3.65, absorption of 1%, unit weight of 1.68 t/m<sup>3</sup>, and voids ratio 31.7%. Sieve analysis had been conducted which its results are shown in Table 2.

Table 2: Sieve Analysis of Sand

Sieve Size (mm)	40	20	10	5	2.5	1.25	0.61	0.31	0.15
% Passing	100	100	100	90	70	50	20	5	0

**2.1.3 Coarse Aggregates**

Dolomite of 15 mm maximum size was used. Its physical properties were tested as specific gravity of 2.72 t/m<sup>3</sup>, fineness modulus of 6.66, absorption 1%, the surface area of 2.06 cm<sup>2</sup>/gm, and crushing factor is equal to 12.50 %. Sieve analysis had been conducted which its results are shown in Table 3.

Table 3: Sieve Analysis of Dolomite

Sieve Size (mm)	40	20	10	5	2.5	1.25	0.61	0.31	0.15
% Passing	99	95	35	5	0	0	0	0	0

**2.1.4 Chemical Admixtures**

Four commercial products were used, they comply with ASTM C494-13 type "G" [10] and EN 934-2 [11]:

- AddiCrete BVS 100: Is Aqueous dispersion of modified polycarboxylate materials, it appears as brown liquid with specific gravity of 1.175 and solid content of 42.5%.
- AddiCrete BV 200: Is Aqueous dispersion of modified polycarboxylate materials, it appears as brown liquid with specific gravity of 1.11 and solid content of 27%.
- SikaViscoCrete 3425: Is Aqueous solution of modified polycarboxylate materials, it appears as clear liquid with specific gravity of 1.05 and solid content of 40%.
- SikaViscoCrete 5930: Is Aqueous solution of modified polycarboxylate materials, it appears as turbid liquid with specific gravity of 1.08.

**2.2 Mixing procedure and moulding**

The coarse and fine aggregates were initially fed into the concrete mixer, and then Portland cement and 3/4 of (water + admixture) were poured into the mixer. While the mixer was operated, the remaining water was added as necessary. The mixing time was 5.0 minutes started from the time when all the mixed materials had been charged into the mixer.

After casting, all the moulded specimens were covered with plastic sheets and were left in the casting room for 24 hours “25°C and 75 % R.H. Afterwards, they were de-moulded and transferred to the moist curing room at 100% relative humidity until required for testing.

**2.3 Concrete mixtures**

An experimental program was undertaken to obtain workability, strength and durability for all mixes. Five mixes were made in this paper. For all mixtures, the graded coarse and fine aggregates were weighted in room dry condition, the coarse aggregate was then immersed in water for 24 hours, the excess water was decanted and the water retained by the aggregates was determined by the mass difference [14]. A predetermined amount of water was added to the fine aggregate that was then allowed to stand for 24 hours. The water to cement ratio was

maintained at 36%, coarse aggregate content (dolomite) was 875 kg/m<sup>3</sup> with 15 mm, fine aggregate content (natural sand) was 950kg/m<sup>3</sup>, tap water has been used for mixing and curing, tap water that used in all of the tests was clean drinking fresh water from impurities. Portland cement was used; the quantity of cement was 500 kg/m<sup>3</sup>. The mixture proportions of the mixtures are as shown in Table 4.

Table 4: The Mix Proportion of Specimens

Mix No	w/c	Quantities kg/m <sup>3</sup>					
		Cement	Water	Dolomite	Sand	Admixtures	
C	0.36	500	180	875	950	===	
M <sub>1</sub>	0.36	500	180	875	950	7	AddiCrete BVS 100
M <sub>2</sub>	0.36	500	180	875	950	7	AddiCrete BV200
M <sub>3</sub>	0.36	500	180	875	950	7	SikaViscoCrete3425
M <sub>4</sub>	0.36	500	180	875	950	7	SikaViscoCrete 5930

**2.4 Test method**

**2.4.1 Fresh concrete**

Self-Compacting Concrete is characterized by flow ability, passing ability and segregation resistance. Many different methods have been developed to characterize the properties of SCC. No single method has been found until date, which characterizes all the relevant workability aspects, and hence, each mix has been tested by more than one test method for the different workability parameters. Table 5 gives the recommended values for different tests given for mix to be characterized as SCC mix.

Table 5: The Range of Values of Workability Tests

	Test	Characteristic	Typical range of values [9]	
			Minimum	Maximum
1	Slump Flow Diameter	Flowability	650 mm	800 mm
2	L-Box (H <sub>2</sub> /H <sub>1</sub> )	Passing ability	0.8	1
3	V-funnel	Flow ability	6 sec	12 sec
4	V-funnel at T <sub>5min</sub> (time increase)	Segregation resistance	0 sec	3 sec

**2.4.1.1 Slump flow diameter**

It is the most commonly used test, and gives a good assessment of flow ability. The slump cone was filled with concrete without tamping; the concrete level at top of the cone was strike off. The cone was raised vertically to allow the concrete to flow out freely. Final diameter of the concrete in two perpendicular directions was measured. The average of the two measured diameters is the slump flow in mm [9]. The apparatus is shown in Fig. 1.

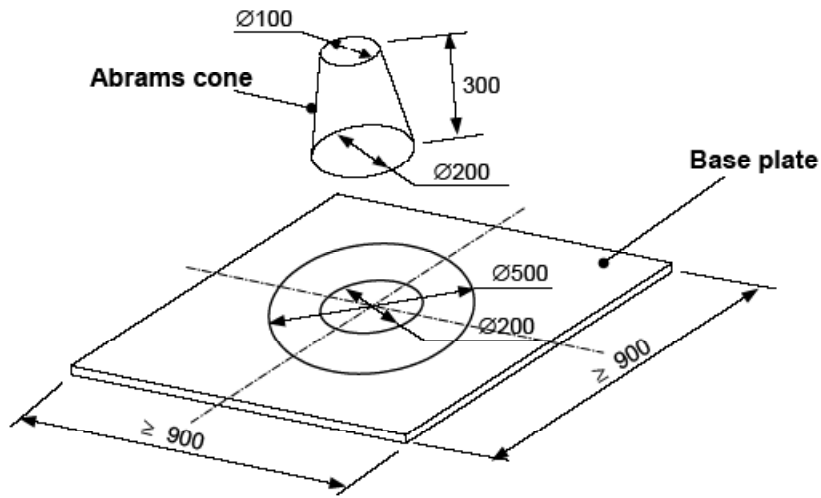

Fig.1: Slump flow test

### 2.4.1.2 L-box

It is a widely used test, and gives a good assessment of passing ability. The vertical section of apparatus was filled with concrete without tamping till level at top. After 1 minute; the sliding gate raised vertically to allow the concrete to flow out into horizontal section freely. When the concrete stopped flowing, the heights of the concrete were measured;  $H_1$  in the vertical section, and  $H_2$  at the end of the horizontal section. The ratio of  $(H_2/H_1)$  is the blocking ratio. The apparatus is shown in Fig.2.

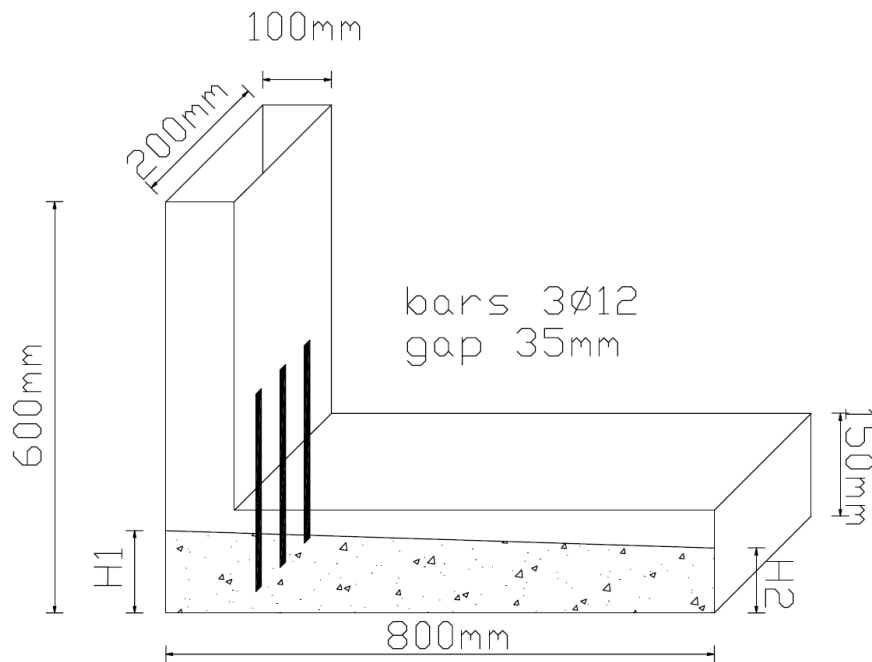
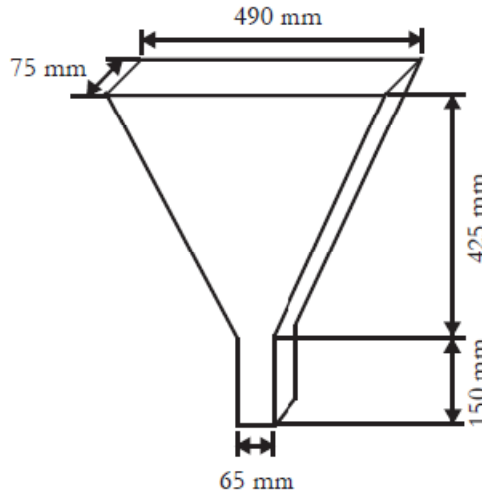

Fig.2: L-Box test

**2.4.1.3 V-funnel and V-funnel at T=5 minutes**

It gives a good assessment of segregation resistance. The funnel was filled with concrete without tamping; the concrete level at top of the funnel was strike off. The time was recorded when the trap door was opened to allow the concrete to flow out freely under gravity, till light is seen from above through the funnel. Immediately, the funnel refilled with the same concrete and left for 5 minutes to settle; then the time was recorded again. Shorter flow time indicates greater flowability [13]. The apparatus is shown in Fig.3.



**Fig. 3: V-funnel test**

**2.4.2 Hardened Concrete**

Self-Compacting Concrete is characterized by strength and durability. For strength requirements compressive, tensile, and flexural strengths were determined. For durability requirements water absorption and sorptivity were determined.

**2.4.2.1 Water absorption**

The cubes of size 150×150×150 mm were used to determine the absorption at age of 28 days. The specimens dried in oven at temperature 105°C until the weight became constant; this weight was noted as dry weight ( $W_d$ ). Then the cubes were immersed in water for 3 days then weighted, this weight was noted as wet weight ( $W_w$ ).

The % Absorption was computed by

$$\% \text{ Absorption} = \frac{W_w - W_d}{W_d} \times 100 \dots\dots\dots \text{Eq.1}$$

**2.4.2.2 Sorptivity**

Sorptivity measures the rate of penetration of water into the pores in concrete by capillarity suction when the cumulative volume of water that has penetrated per unit surface area of exposure is plotted against the square root of time of exposure. The resulting graph

could be approximated by a straight line passing through the origin. The slope of this straight line is considered as a measure of rate of movement of water through the capillary pores.

The cubes of size 150×150×150 mm were used to determine the sorptivity at age of 28 days [12]. The specimens dried in oven at temperature 105°C then side surfaces were sealed, and the end of the specimens opposite the absorbing surface was covered to impede evaporation from this surface during the test. The specimens were supported on rods that it was submerged about 5 mm as shown in Fig.4.

The sorptivity was computed by

$$S = \frac{Q}{A * \sqrt{t}} \text{ mm} / \text{min}^{0.5} \dots\dots\dots \text{Eq.2}$$

S = Sorptivity in (mm/min<sup>0.5</sup>)

Q = Volume of water penetrated in (mm<sup>3</sup>)

A = Surface area in (mm<sup>2</sup>)

t = time elapsed in (min)

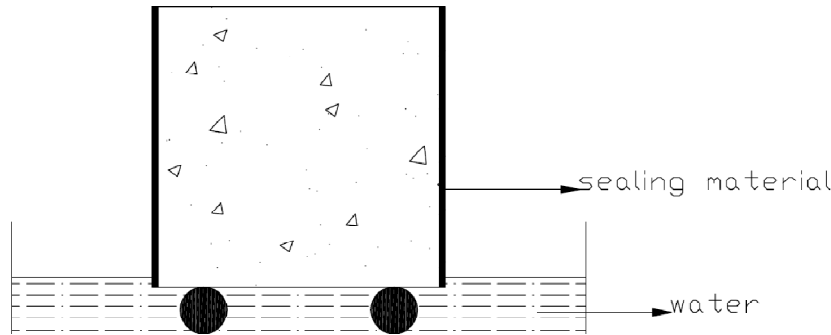

Fig.4: Sorptivity test

**3. Results and discussion**

**3.1 Properties of fresh concrete**

Concrete mixes at fresh state were tested as slump flow diameter, L-box and V-funnel, Table 6 provides an overview of test results. Figures 5-7 provide a comparison of different tests for concrete mixes.

Table 6: Tests Results at Fresh State

Mix. No.	Slump Flow Diameter (mm)	L-Box (H <sub>2</sub> /H <sub>1</sub> )	V-funnel (sec)	V-funnel at T <sub>5min</sub> (sec)
C	675	0.80	10	12.5
M1	690	0.90	10.5	12
M2	654	0.86	11	14
M3	681	0.90	11	13
M4	670	0.83	7	8

### 3.1.1 Slump flow diameter

The slump flow diameter test was carried out according to European Federation of National Associations Representing for Concrete (EFNARC). The results measured are shown in Table 6. In general, the slump flow diameters of mixes are in the range of 654:690 mm. Figure 5 shows the different values for each mix.

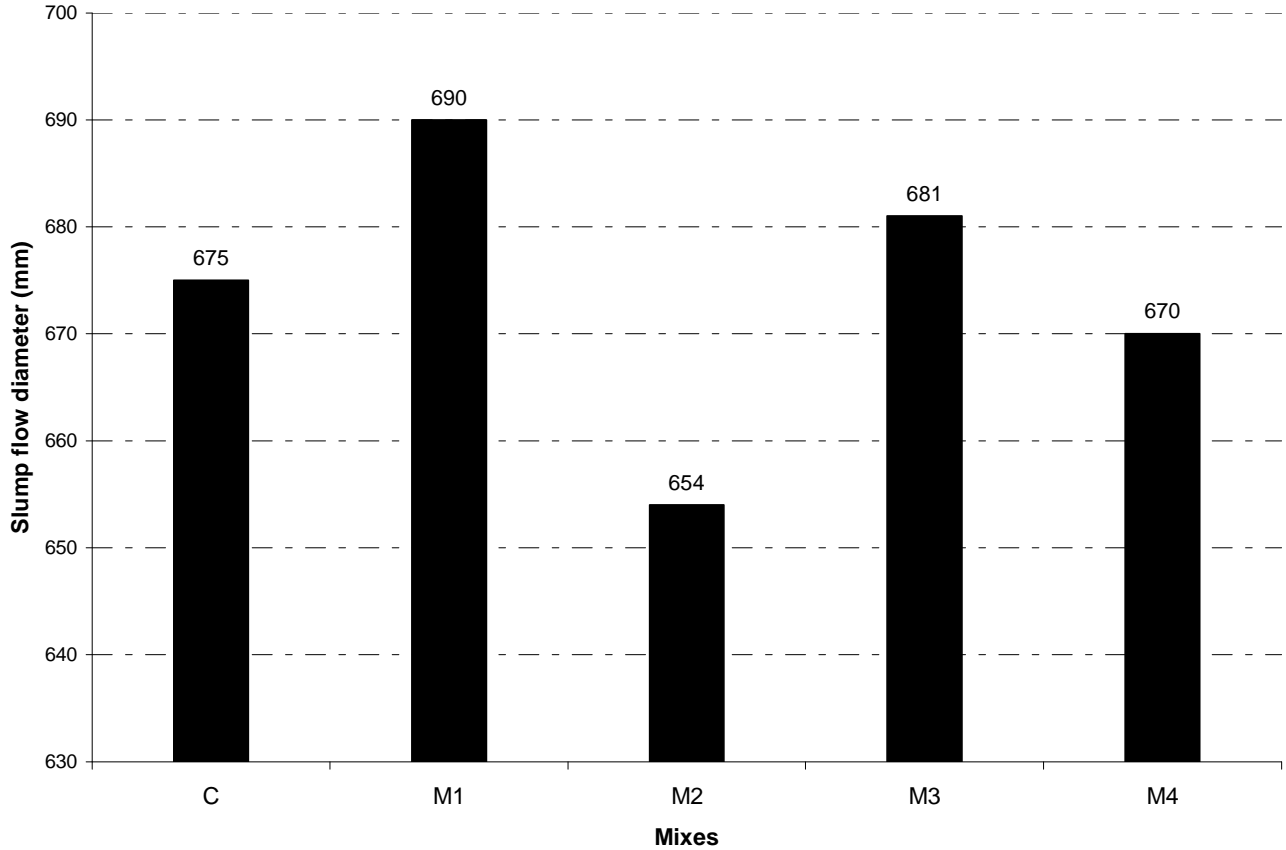

Fig.5: Slump diameter test results

### 3.1.2 L-box

The L-Box test was carried out according to EFNARC. The results measured of blocking ratio are shown in table 6. In general, the blocking ratios of mixes are in the range of 0.8:0.9. Figure 6 shows the different values for each mix.

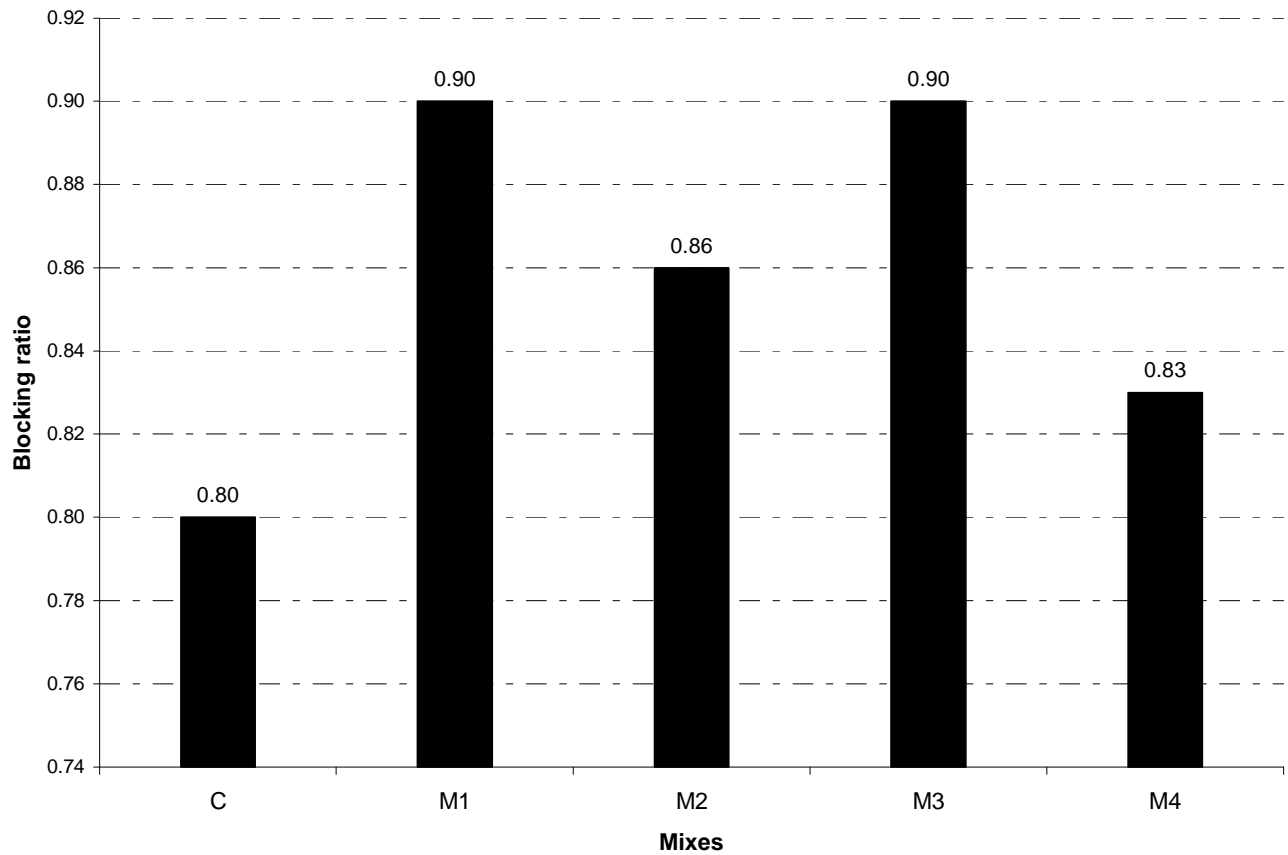

Fig. 6: L-box test results

**3.1.3 V-funnel and V-funnel at T=5 minutes**

The V-funnel test was carried out according to EFNARC. The results measured of flow time are shown in Table6. In general, the flow times of mixes are in the range of 7:11sec after 10 sec; and in the range of 8:14 sec after 5 minutes. Figure 7 shows the different values for each mix.

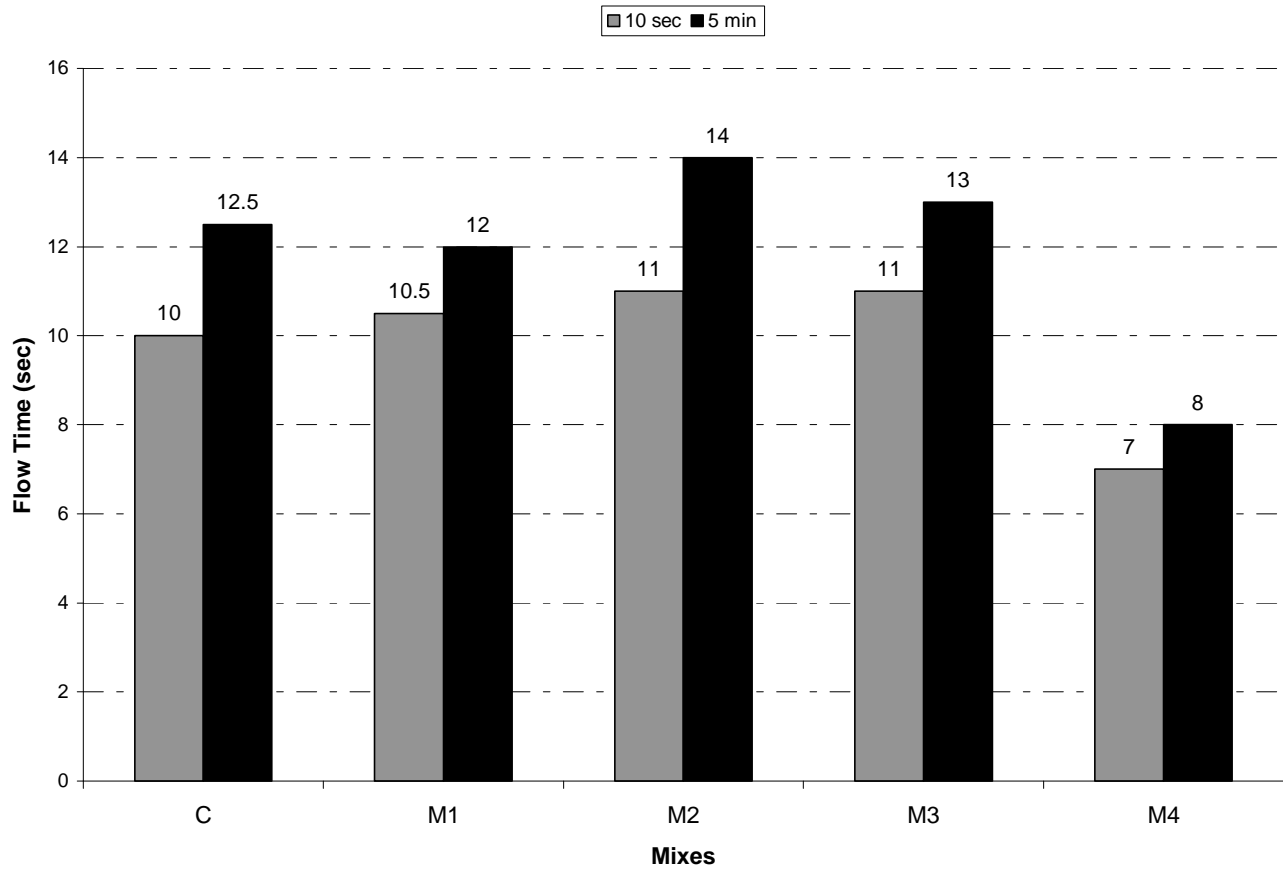

Fig.7: V-funnel test results

3.2 Properties of hardened concrete

Concrete mixes at hardened state were tested as compressive strength, flexural strength and splitting tensile strength at different ages “7 & 28 days”, table 7 provides an overview of test results. Figures 8-12 provide a comparison of different tests for concrete mixes.

Table 7: Tests Results at Hardened State

Mix. No.	Compressive Strength (kg/cm <sup>2</sup> )		Tensile Strength (kg/cm <sup>2</sup> )		Flexural Strength (kg/cm <sup>2</sup> )	% Absorption	Sorptivity(mm/ $\sqrt{\text{min}}$ )
	7Days	28Days	7Days	28Days	28Days	28Days	28Days
C	350	445	25.38	28.21	36.3	5.495	0.2436
M1	315	458	36.14	42.22	53.0	5.307	0.1947
M2	149	212	27.83	30.67	30.5	8.433	0.2865
M3	437	506	28.97	31.56	50.3	4.020	0.1896
M4	319	369	21.98	24.06	42.5	6.688	0.3035

### 3.2.1 Compressive Strength

The compressive strength test carried out by ASTM C39-04. Its results are shown in Table7. The compressive strengths for all mixtures are at range of 149 to 437kg/cm<sup>2</sup> after 7 days and at range of 212 to 506kg/cm<sup>2</sup>after 28 days. Figure 8 shows a comparison of achieved compressive strength for each mix.

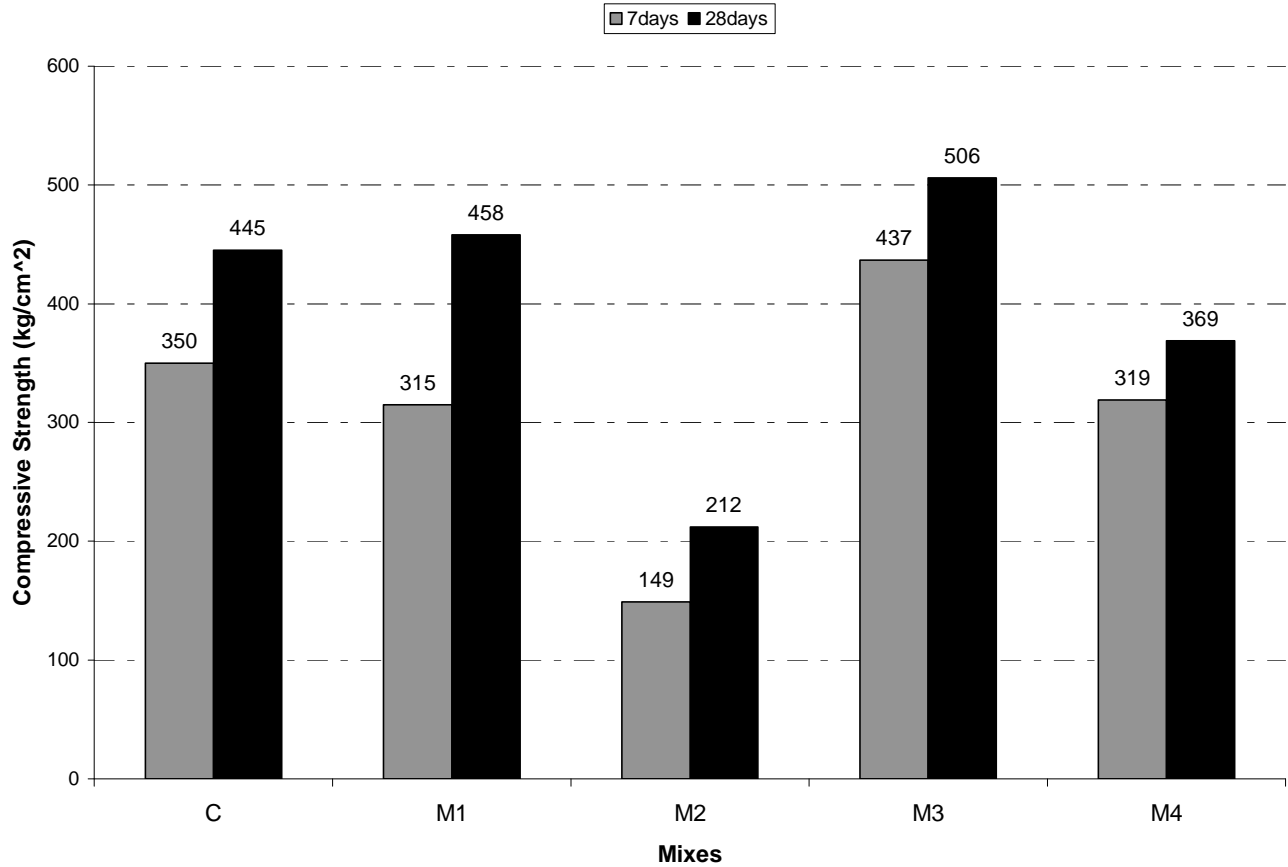
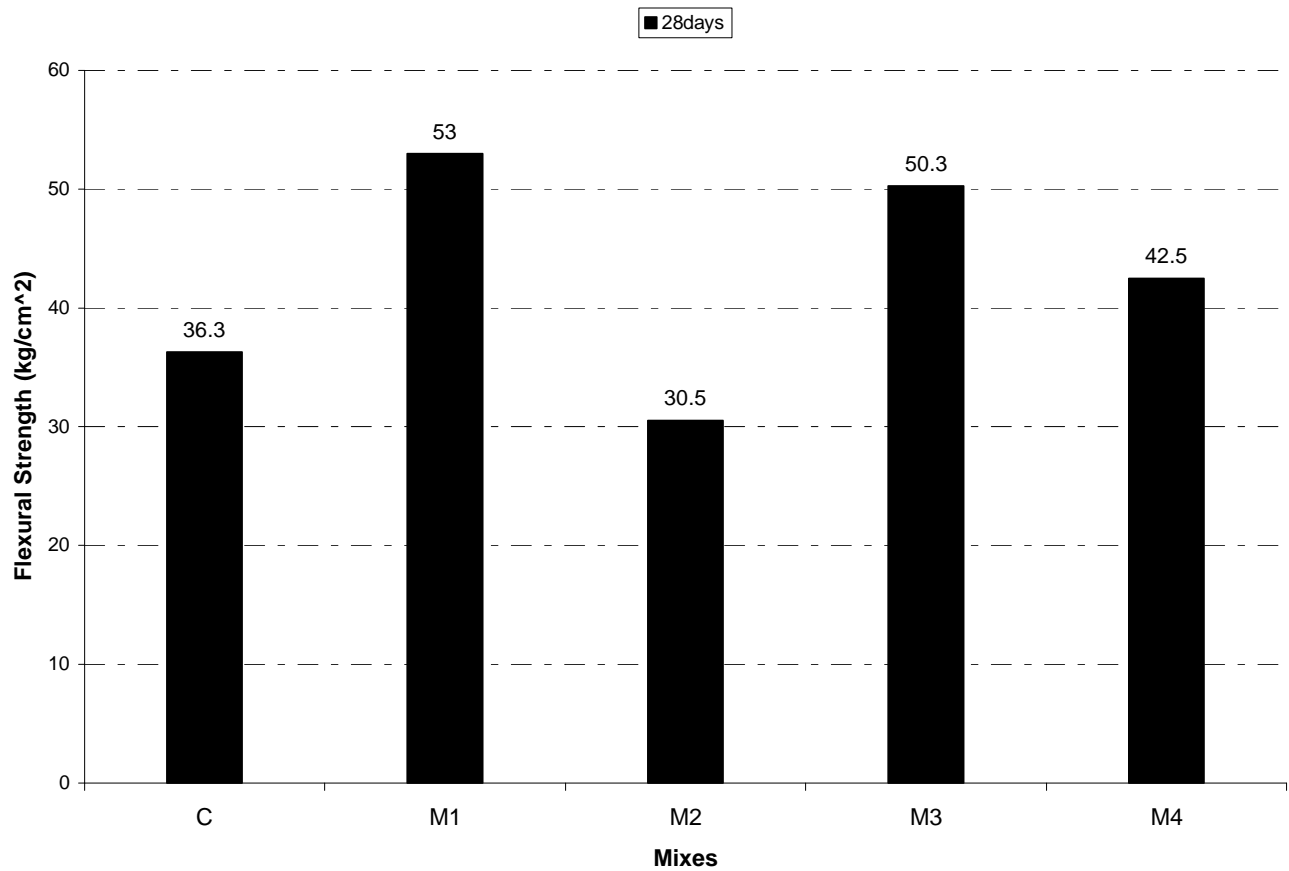

Fig.8: Compression test results

### 3.2.2 Flexural Strength

The flexural strength test carried out by ASTM C78-07. Its results are shown in Table7. The flexural strengths for all mixtures are at range of 30.5 to 53.0kg/cm<sup>2</sup> after 28 days. Figure 9 shows a comparison of achieved flexural strength for each mix.



**Fig.9: Bending test results**

**3.2.3 Splitting Tensile Strength**

The tensile strength test carried out by ASTM C496-11. Its results are shown in Table7. The tensile strengths for all mixtures are at range of 21.98 to 36.14kg/cm<sup>2</sup> after 7 days and at range of 24.06 to 42.22 kg/cm<sup>2</sup> after 28 days. Figure 10 shows a comparison of achieved tensile strength for each mix.

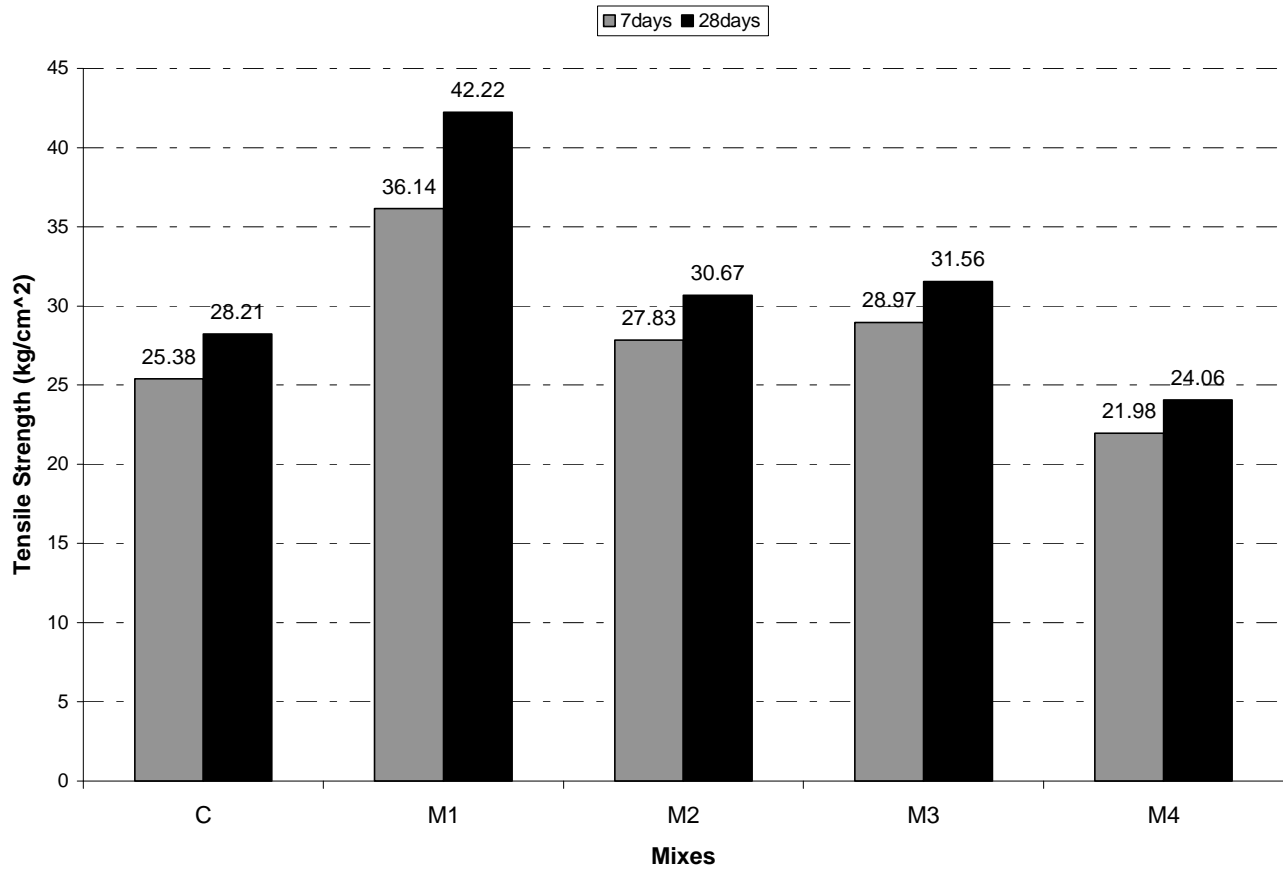
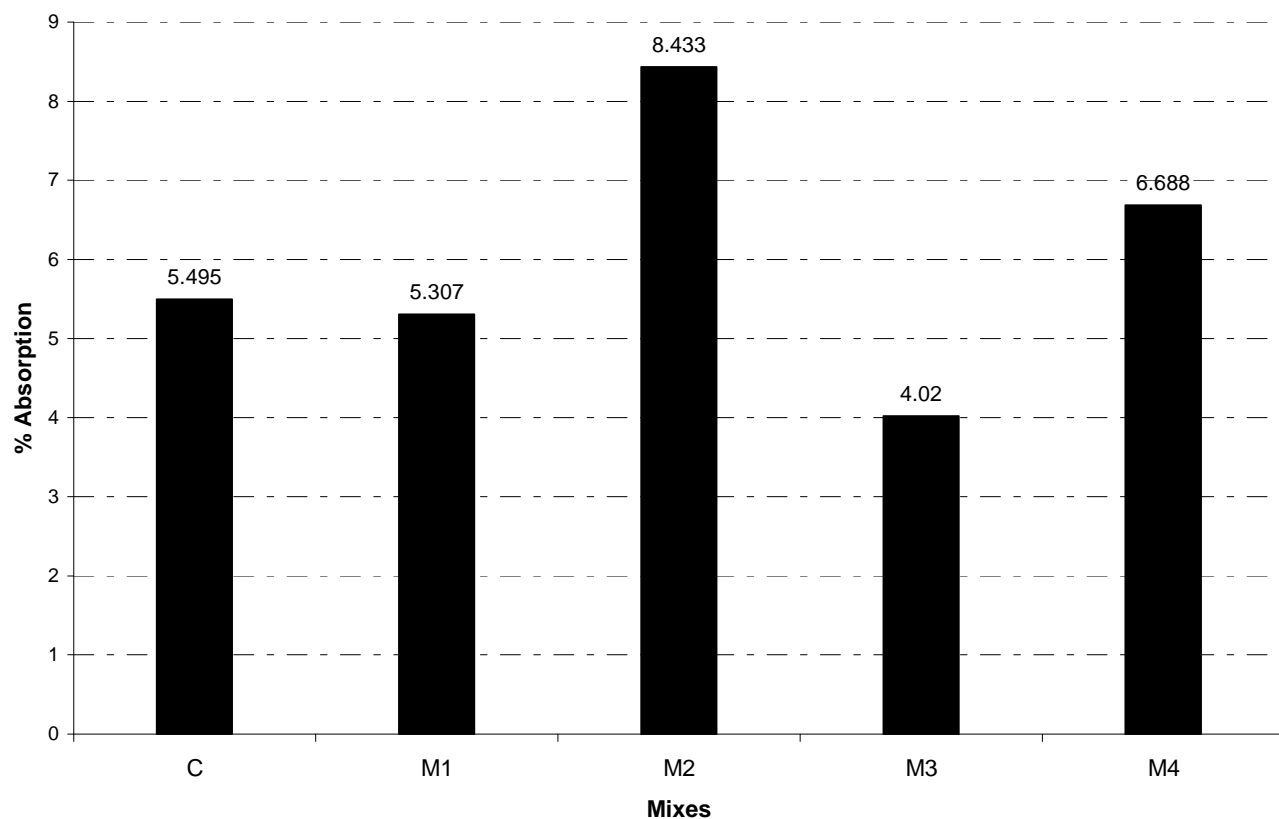

Fig.10: Tension test results

### 3.2.4 Absorption

The water absorption test carried out by ASTM C642-06. Its results are shown in Table7. The water absorption percentages for all mixtures are at range of 4.02% to 8.433% after 28days. Figure 11 shows a comparison of water absorption percentages for each mix.



**Fig.11: Absorption test results**

### 3.2.5 Sorptivity

The sorptivity test carried out by ASTM C1585-04 [12]. Its results are shown in Table 7. The sorptivity values for all mixtures are at range of 0.1896 to 0.3035 mm/ $\sqrt{\text{min}}$  after 28days. Figure 12 shows a comparison of sorptivity values for each mix.

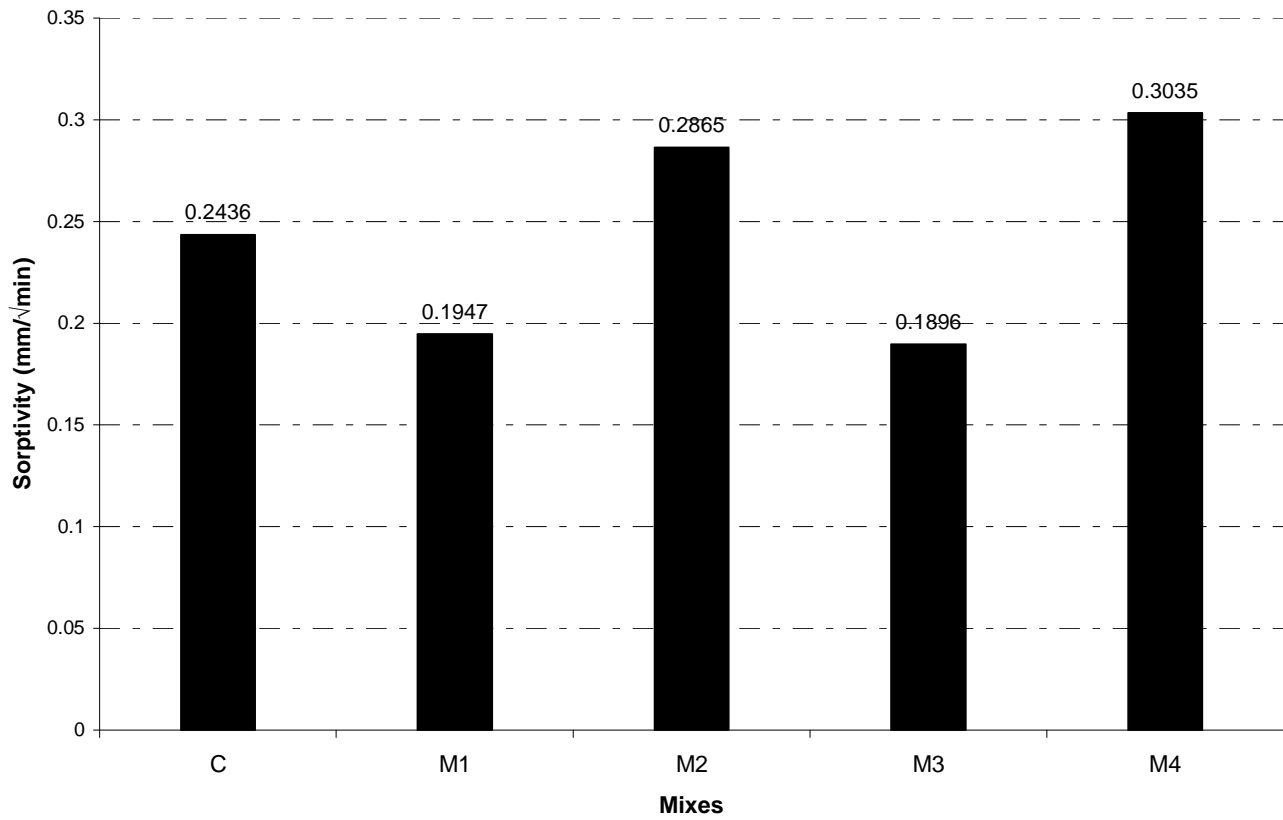

Fig.12: Sorptivity test results

#### 4. Conclusions

Using AddiCrete BVS 100, Compressive strength decreased by (10.00%) at age of 7 days, and increased by (2.92%) at age of 28 days; Tensile strength increased by (42.40%) at age of 7 days, and increased by (49.66%) at age of 28 days; Flexural strength increased by (46.01%) at age of 28 days. % Absorption decreased by (3.42%) at age of 28 days, Sorptivity decreased by (20.07%) at age of 28 days. Flow ability increased, passing ability increased.

Using AddiCrete BV200, Compressive strength decreased by (57.43%) at age of 7 days, and decreased by (52.36%) at age of 28 days; Tensile strength increased by (9.65%) at age of 7 days, and increased by (8.72%) at age of 28 days; Flexural strength decreased by (15.98%) at age of 28 days. % Absorption increased by (53.47%) at age of 28 days, Sorptivity increased by (17.61%) at age of 28 days. Flow ability decreased, passing ability increased.

Using SikaViscoCrete 3425, Compressive strength increased by (24.86%) at age of 7 days, and increased by (13.71%) at age of 28 days; Tensile strength increased by (14.14%) at age of 7 days, and increased by (11.88%) at age of 28 days; Flexural strength increased by (38.57%) at age of 28 days. % Absorption decreased by (26.84%) at age of 28 days, Sorptivity decreased by (22.17%) at age of 28 days. Flow ability increased, passing ability increased.

Using SikaViscoCrete 5930, Compressive strength decreased by (8.86%) at age of 7 days, and decreased by (17.08%) at age of 28 days; Tensile strength decreased by (13.40%) at age of 7 days, and decreased by (14.71%) at age of 28 days; Flexural strength increased by (17.08%) at age of 28 days. %

Absorption increased by (21.71%) at age of 28 days, Sorptivity increased by (24.59%) at age of 28 days. Flow ability decreased, passing ability increased.

From the previous investigation and test result, it can be concluded that SikaViscoCrete3425 and AddiCrete BVS 100 improved the workability and strength properties of SCC.

Scope of the future work, the durability of concrete should be studied.

## References

- [1] H Okamura and M Ouchi. 'Self-compacting Concrete. Development, Present use and Future'. Proceeding of the First International RILEM Symposium on 'Self-Compacting Concrete'. Sweden, Proc 7, 1999, pp 3-14.
- [2] K Ozawa, M Kunishima, K Maekawa and K Ozawa. 'Development of High Performance Concrete Based on Durability Design of Concrete Structures'. Proceeding of East-Asai and Pacific Conference on Structural Engineering and Construction (EASEC-2), vol 1, January 1989, pp 445-450.
- [3] The European Project Group (2005). The European Guidelines for Self Compacting Concrete. SCC European Project Group.
- [4] K Takada, G I Pelova and J C W Walraven. 'Influence of Chemical Admixtures and Mixing on the Mix Proportion of General Purpose Self-Compacting Concrete'. International Congress 'Creating with Concrete', University of Dundee, UK, September 6-10, 1999.
- [5] N Sakata, K Maruyama and K Minami. 'Basic Properties and Effects of Welan Gum on Self-consolidating Concrete'. Proceedings of the International RILEM Conference on 'Production Methods and Workability of Concrete', edited by P J M Bartos, D L Marrs and D J Cleland, E & FN Spon, Paisley, Scotland, June 3-5, 1996, pp 237-253.
- [6] Dias W.P.S. Reduction of concrete sorptivity with age through carbonation, Cement and Concrete Research 30(2000) 1255-1261.
- [7] Martys N.S, Ferraris C.F, Capillary transport in mortars and concrete, Cement and Concrete Research 27 (5) (1997) 747-760.
- [8] Tasdemir C., Combined effects of mineral admixtures and curing conditions on the sorptivity coefficient of concrete, Cement and Concrete Research 33 (2003) 1637-1642.
- [9] EFNARC (European Federation of national trade associations representing producers and applicators of specialist building products), Specification and Guidelines for self-compacting concrete, February 2002, Hampshire, U.K.
- [10] ASTM C494-13 "Standard Specification for Chemical Admixtures for Concrete," ASTM, Philadelphia, USA.
- [11] EN 934-2: European Standard "Admixtures for concrete, mortar and grout - Part 2: Concrete admixtures - Definitions, requirements, conformity, marking and labeling"

- [12] ASTM C1585-04, “Standard Test Method for Measurement of Rate of Absorption of Water by Hydraulic Cement Concretes,” ASTM International, West Conshohocken, PA.
- [13] K Ozawa, N Sakata and H Okamura. ‘Evaluation of Self-Compatibility of Fresh Concrete Using the Funnel Test’. Concrete Library of JSCE, vol 25, June 1995, pp 59-75. March 2-3, 1993, pp183-190.
- [14] H Okamura and K Ozawa. ‘Mix Design for Self-Compacting Concrete’. Concrete Library of JSCE, no 25, June 1995, pp 107-120.